

A wide-angle photograph of a modern university campus. In the center background, a tall, slender clock tower with a grid-like facade rises against a clear blue sky. The foreground and middle ground are dominated by a large, landscaped commons area. This area features a series of terraced, brick-walled planters and walkways that create a sense of depth and structure. The ground is covered in vibrant green grass, and numerous young trees are planted in the planters. To the right, a paved plaza area is visible, furnished with tables and chairs under large orange umbrellas. The overall scene is bright and sunny, with long shadows cast across the grass, indicating it is either early morning or late afternoon.

UNIVERSITY OF CALIFORNIA, RIVERSIDE

COMMONS MALL & BOOKSTORE RENOVATION AND ENHANCEMENT DPP
PROJECT NO. 950500

JULY 11, 2011

TABLE OF CONTENTS

1. INTRODUCTION
2. EXECUTIVE SUMMARY
3. SITE ANALYSIS
4. SITE ENHANCEMENTS
5. BUILDING IMPROVEMENTS
6. ENVIRONMENTAL GRAPHICS
7. VISION PLAN
8. SUPPORTING DOCUMENTS
9. CONCEPTUAL COST PLAN
10. IMPLEMENTATION
11. APPENDIX

1. INTRODUCTION





INTRODUCTION

The Commons Mall and Campus Bookstore Renovation and Enhancement Detailed Project Program (DPP) defines a scope of work to improve both the Commons Mall and the 1991 Bookstore building at the University of California, Riverside (UCR) as well as to incorporate the campus Career Center at the lower level of the building.

Over the course of 8 months, the Project Management Team (PMT) and Building Committee members studied desired program components, edge conditions and infrastructure

associated with both the site and the building. The result is a scope of improvements that fits within a larger master plan vision that will enable the area around the Highlander Union Building to serve an expanding campus population of students, faculty, administrators, alumni, visitors, and prospective students.

The Design Consultant Team wishes to thank the many UCR participants who shared their ideas and knowledge of the campus to develop this study.

PARTICIPANTS UCR

PROJECT MANAGEMENT TEAM

- Jim Sandoval Vice Chancellor, Student Affairs
- Danny Kim Assistant Vice Chancellor, Student Affairs
- Tim Ralston Associate Vice Chancellor, Capital Resource Management
- Nita Bullock Director of Physical Planning/Campus Landscape Architect (Project Manager)
- Don Caskey Associate Vice Chancellor/Campus Architect
- Jacqueline Norman Senior Project Manager, Design and Construction
- Uma Ramasubramanian Senior Planner, Capital Resource Management

COMMITTEE

- Todd Wingate Director HUB
- Scott Campbell Director Campus Bookstore
- Randy Williams Director Career Center
- Cheryl Garner Director Dining Services
- John Ganim Academic Senate Representative
- John Faheem ASUCR Representative
- Gary Coyne GSA Representative

CAMPUS REPRESENTATIVES

- Mike Delo Director, Transportation and Parking Services
- Tos Ishida Assistant Director, Physical Plant and Grounds Department
- Earl Levoss Physical Plant Superintendent
- Scott Corrin Campus Fire Marshall
- John Freese Campus Police Department
- John Cook Campus Sustainability Manager
- Joe Steinmeyer Facility Manager HUB
- Nicole Seebach Student
- Liliana Barcelo Student

CONSULTANT TEAM

FIELD PAOLI ARCHITECTS

- Avery Taylor Moore Principal in Charge
- Steven Lovell Design Principal
- Paul Cooper Senior Associate (Project Manager)

SWA LANDSCAPE ARCHITECTS

- David Berkson Principal in Charge
- Amy Oliver Associate (Project Manager)

RSM ENVIRONMENTAL GRAPHICS

- Suzanne Redmond Schwartz Principal

CONSULTING TEAM MEMBERS

- Neha Yardav KPFF, Civil
- Kelly Weldon NYASE, Structural
- Tony Cocea IBE, Mechanical
- Zelik Uber IBE, Plumbing
- Paul Carey OMM, Electrical
- Patricia Djojopranoto Davis Langdon, Cost Estimating
- Dick Kremer Kremer & Associates, College Store Design

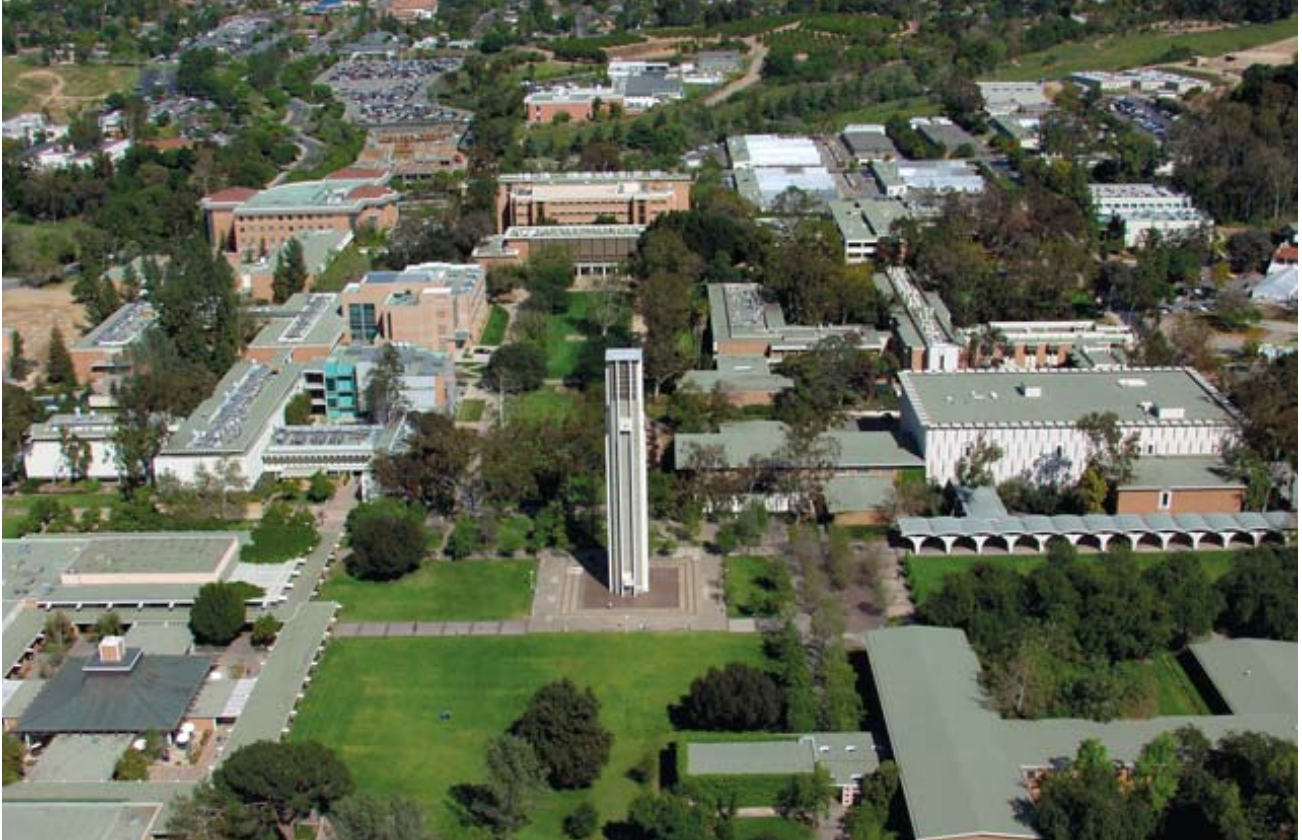

AERIAL VIEW OF CARILLON MALL LOOKING EAST - FORMER STUDENT COMMONS AT LEFT

PROCESS

1. METHODOLOGY

The programming and budget phase began with a review of existing campus documents and a site walk to record visible field conditions. The PMT and Committee were asked to share their visions and expectations for the project. The Design Consultant Team then developed a “kit of parts” including concept diagrams and photographs to evaluate the project program and desired uses and adjacencies. Technical consultants next prepared narrative summaries describing existing conditions and conceptual improvements to building systems. These narratives were used to develop the preliminary cost estimate and inform the selected scope of work; they are included in Section 8 of this Detailed Project Program (DPP).

2. IMPLEMENTATION

The design and working drawings phase will include program verification, schematic design, design development, and construction drawings. This work will commence

following formal approval of the project budget, scope and schedule and it is estimated that it will take approximately 9 months. Project construction is anticipated to start in early summer 2012 and continue for approximately 10 months, with completion targeted in spring 2013.

3. TASKS

The study was divided into 15 tasks which led from the project vision to completion of the DPP. This process included six (6) on-campus meetings, including two days interviewing focus groups. [See Task Chart in Appendix]

In early February 2011, concept diagrams and the project approach were presented to the UCR Design Review Board (DRB); their comments were reflected in the proposed scope and cost estimate that were approved by the Capital Program Advisory Committee (CPAC) in April 2011. Minutes for all on-campus meetings and conference calls are included in the Appendix of this report.

2. EXECUTIVE SUMMARY





AERIAL VIEW OF COMMONS MALL LOOKING SOUTH - CONCEPTUAL DESIGN

VISION

UCR is a growing campus. The student population has grown from 17,500 in 2008 to 20,500 in 2011, and it is expected to reach 25,000 in 2020. As part of UCR's strategic planning, campus leaders, planners and designers embraced the idea of a new, energetic student center at the site of the original Student Commons along the edge of the central Carillon Mall. This new student center, now called the Highlander Union Building (HUB), was completed in 2007.

The HUB's success as a student gathering place led to this study which had two stated purposes:

- To upgrade the Commons Mall, for many years a construction staging site for new buildings, and now in need of its own improvements and enhancements; and
- To improve the Bookstore building, allowing students to circulate through the building for better access to all tenants.

The initial program called for the Career Center (currently sharing the Veitch Student Center facility with student health and counseling services) to relocate to the lower floor of the Bookstore. The final program locates all retail sales, including text books and the computer store, at the upper floor, and adds the campus Card Office (currently located in the HUB) to the lower floor of the Bookstore.

Study participants recognized that strategic improvements could successfully wrap the Bookstore and an improved Lower Plaza into what will become a larger HUB District. The study also developed a longer term Vision Plan to ensure compatibility of the current project with future growth over time.

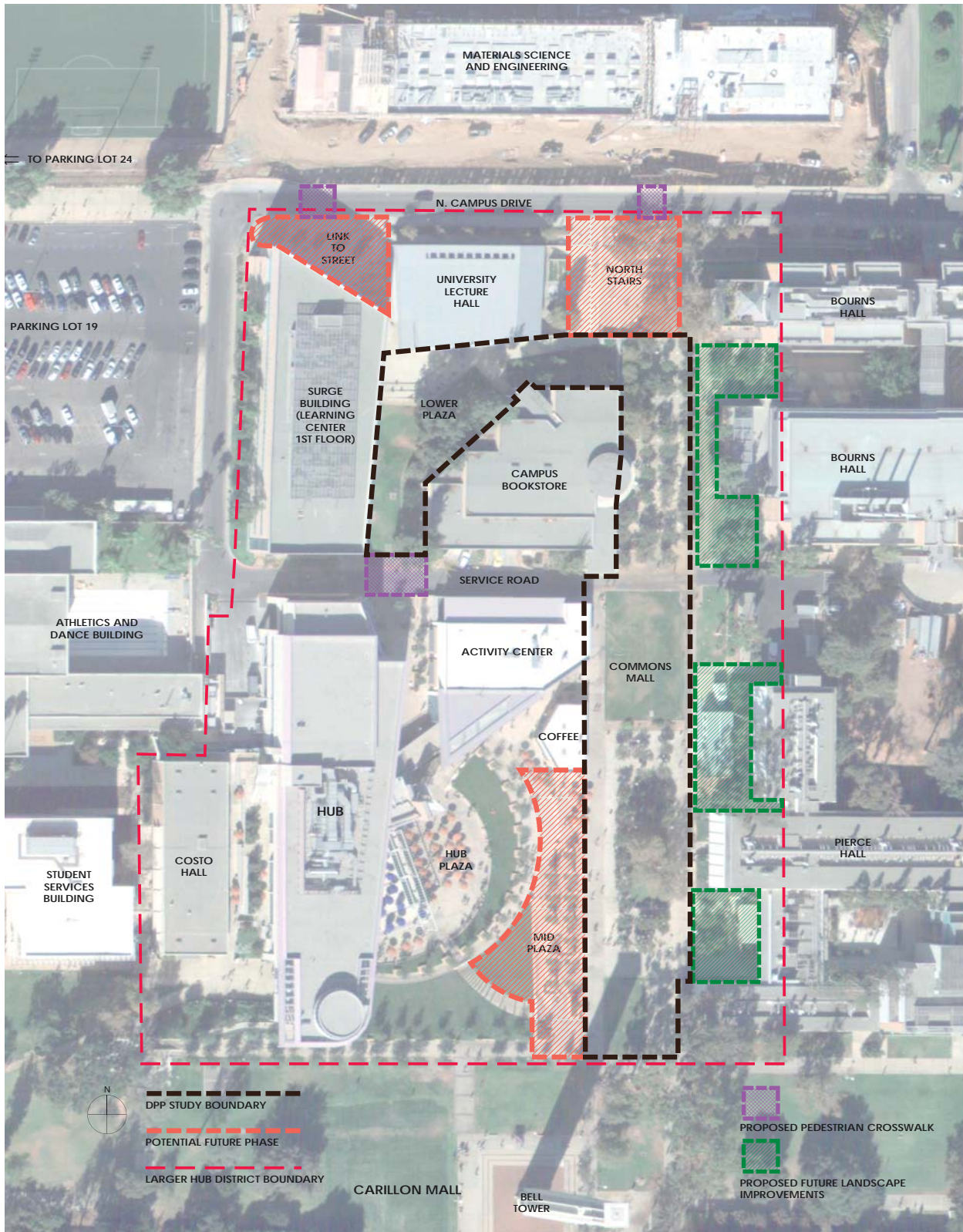

STUDY BOUNDARY



PROJECT SITE



The project is located at the heart of the UCR campus, just north of the Carillon Mall and signature Bell Tower. It is at the heart of the East Campus Academic Core, easily accessible by a 5 to 10 minute walk from many campus facilities.

COMMONS MALL

The Commons Mall is bordered on the west by the existing HUB Plaza Complex, on the east by small courtyards attached to individual science buildings, and on the north by North Campus Drive. On the south, the Commons Mall intersects the Carillon Mall and continues south as the Library Mall.

BOOKSTORE BUILDING

The upper level of the Bookstore building is located on the northern edge of the existing HUB Complex, with

its front door on the Commons Mall. The lower level of the Bookstore shares the Lower Plaza with the University Lecture Hall fronting North Campus Drive and the Surge Building First Floor Learning Center to the west.

HUB DISTRICT

As envisioned, the larger HUB District will include the HUB, Activity Center, Coffee Bean & Tea Leaf (Coffee); the Bookstore, Surge Building and Lecture Hall; also Costo Hall and the area extending west to the adjacent Student Services Building.

Following is a list of Goals that informed the project study. Design Strategies are included for each goal.

GOALS AND DESIGN STRATEGIES

GOAL 1: UPGRADE AND REVITALIZE THE COMMONS MALL

- Strengthen and enhance the Commons Mall as a busy pedestrian link from all sides of the campus and as an important multiuse gathering place within the HUB District.
- Reflect and be compatible with the design sensibility and material quality of the Hub Plaza

GOAL 2: IMPROVE THE CAMPUS BOOKSTORE BUILDING

- Concentrate all retail services on the upper floor and make them more vibrant, visible and accessible.
- Create a pass through from the Lower Plaza to Upper Commons mall through the Bookstore.

GOAL 3: RELOCATE THE CAREER CENTER TO THE LOWER FLOOR

- Relocate the Career Center to the lower floor to reach a larger audience and engage students earlier in the process of future employment.
- Strengthen the important exchange between prospective employers and students with a strong sense of place that is UCR.
- Provide easy access to prospective employers via Parking Lot 24.

GOAL 4: ACTIVATE THE LOWER PLAZA

- Reposition the Lower Plaza to be an active but quieter outdoor gathering place – a counterpoint to the HUB and HUB Plaza – including seating, eating and event space.
- Recognize the Lower Plaza as an important connection, across the Service Road, to the HUB and improve pedestrian access.
- Relocate the Card Office to the Lower Plaza for increased student access and visibility.

GOAL 5: STRENGTHEN CONNECTIONS TO THE LARGER CAMPUS

- Plan for increased pedestrian traffic throughout the HUB District.
- Expand the HUB signage and graphics program to announce HUB student services including retail tenants, recreation uses and the Career Center.
- Improve wayfinding and define entry points and pathways to the HUB District with distinct site features and signage.
- Enhance the UCR image and identity.
- Accommodate planned enrollment growth while retaining flexibility for unanticipated future needs.
- Emphasize strong connections and ease of access within the campus.

GOAL 6: INCREASE AWARENESS OF SUSTAINABILITY

- Create a regional model of planning, design and environmental stewardship protecting the natural environment and incorporating sustainable planning and design practices;
- Select landscape and building improvements to be consistent with campus sustainability guidelines. Designs should be educational and reflect students' interest in sustainable approaches to their environment and lifestyles.

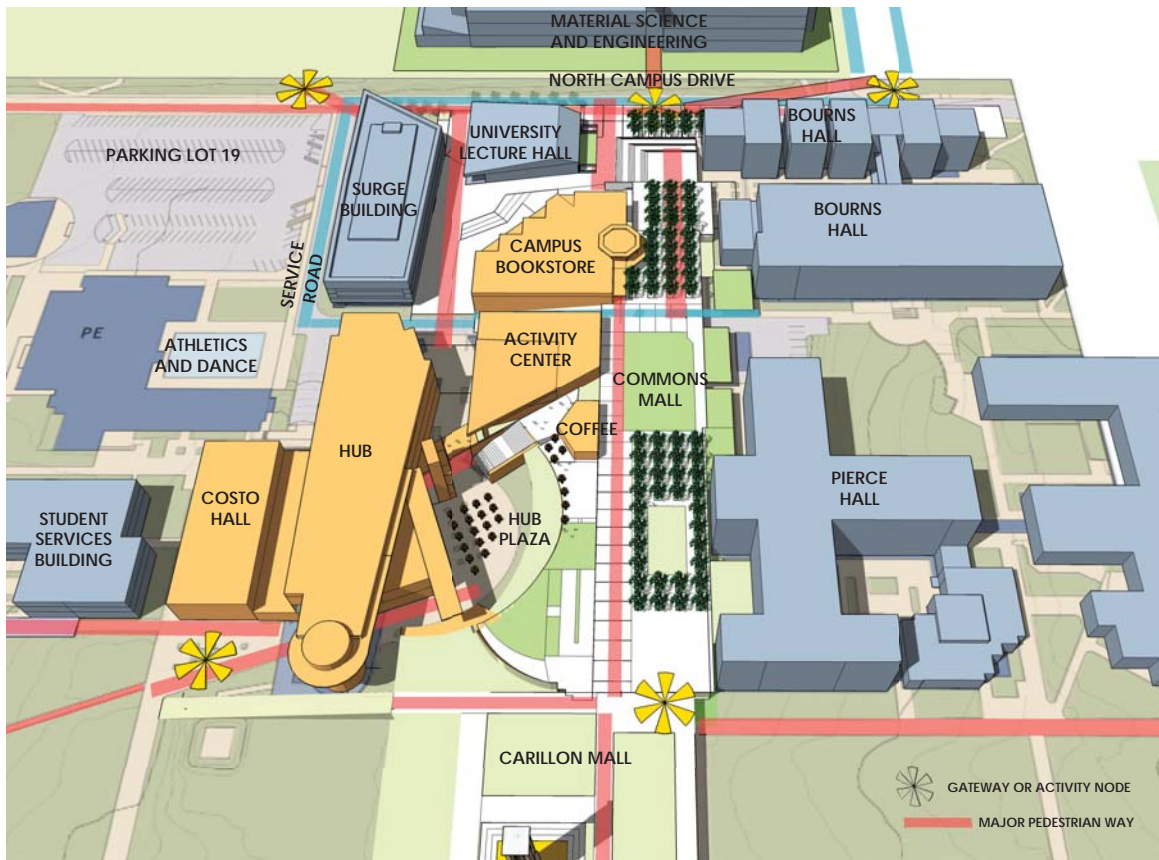

BUILDING PROGRAM SUMMARY

The upper floor of the Bookstore building is approximately 20,000 gross square feet (GSF), of which 12,400 GSF of sales area will be re-merchandised with limited infrastructure improvements. The Rotunda entrance and existing stairway leading down to the lower level are approximately 1,600 GSF; this area will be refurbished with new finishes and lighting. Administrative and service areas will remain as is.

The lower floor of the Bookstore building is approximately 12,725 GSF, banked into the hillside on its north and east sides. Existing text and computer sales areas will be moved to the upper floor, and the lower floor will be remodeled for use by the 6,830 ASF Career Center and the 935 ASF Card Office. Renovation will include new building systems, new accessible toilet rooms and all new finishes at this level, including enlarged windows and doors to the Lower Plaza. Back of house service and utility rooms will remain as is, with replacement equipment as needed.

A new 360 GSF lobby and elevator addition for ADA access will serve both floors.

SITE ENHANCEMENTS

The Commons Mall totals approximately 65,000 SF which will be improved with new hardscape and landscape, including replacement of existing aged trees and preservation of existing mature specimen trees where possible. The Lower Plaza, approximately 19,000 SF of landscape and hardscape, will be re-graded and utilities relocated to allow better visibility and access to the Bookstore building and to the Service Road. Improvements at both levels will include expanded seating choices, new event space, improved pathways, and new lighting, power, and irrigation lines.

ENVIRONMENTAL GRAPHICS

The existing HUB Sign Program will be expanded to provide new tenant signage on all sides of the Bookstore building. It will include a new raised sign armature on the perimeter of the Rotunda roof. New signage and an expanded storefront will also be installed at Latitude 55 in the Activity Center. Opportunities to install sign pylons and banners announcing the HUB District from surrounding street frontages will be explored within resources available to the project.

3. SITE ANALYSIS



CHALLENGES

- 1. CAMPUS PLANNING:** The historic network of campus landscape malls should be respected and maintained. At the same time, new paths and uses, a growing emphasis on open space/sustainable landscapes, and a pervading need for shade in UCR's hot, desert-like climate will provide direction for future improvements.
- 2. RETAILING AND REVENUE:** As markets rapidly change with internet learning and purchasing, the Bookstore building must be well known and accessible. It should continue to play a major role as a valuable and convenient resource for educational supplies, computer services, and campus spirit symbolized in clothing and gifts.
- 3. EXPANDING AUDIENCE:** As the UCR campus population increases and future facilities are developed, the HUB as the premiere student center on campus also needs to expand its reach. It can provide greater opportunities for indoor and outdoor relaxation and study, food choices, student events, technology services, and outreach to alumni, prospective, current and graduating students.

The Career Center should also move from its remote location to take advantage of the large numbers of campus constituents who gather daily at the HUB. This move will vacate space to allow the Health Center to expand.

- 4. CIRCULATION AND CONNECTIONS:** Every new building results in new campus circulation routes. The recent opening of the Material Sciences and Engineering Building, directly across North Campus Drive from the terminus of the Commons Mall, has already greatly increased pedestrian traffic coming south to the HUB District. Planned building construction will continue this trend, increasing demand on both the Commons Mall and Lower Plaza for programmed uses and circulation. A particular challenge is to connect the Campus Bookstore Building and Lower Plaza across the divide of the existing Service Road to become a recognized part of a larger HUB District. Improvements to the Service Road, including crosswalk upgrades and access gates, will be part of the Parking Lot 19 improvement project scheduled to be implemented before this project.
- 5. SENSE OF COMMUNITY:** With many students living off-campus or in residential halls with separate dining facilities and study areas, student unions must provide the face-to-face space to maintain the larger sense of the campus community. In the heart of the campus, the HUB often acts as the home away from home for all campus constituents, whether that home is on-campus, in Riverside or further away. As an active gathering place, the HUB recently developed a sign program specific to its site. Continuing this bold HUB signage and graphics program is essential to enhance the District, increase wayfinding, and assist in strengthening and celebrating the spirit of UCR.
- 6. SUSTAINABLE DESIGN:** As campus development continues, site and building improvements as well as facility operations and maintenance, must follow a sustainable approach.

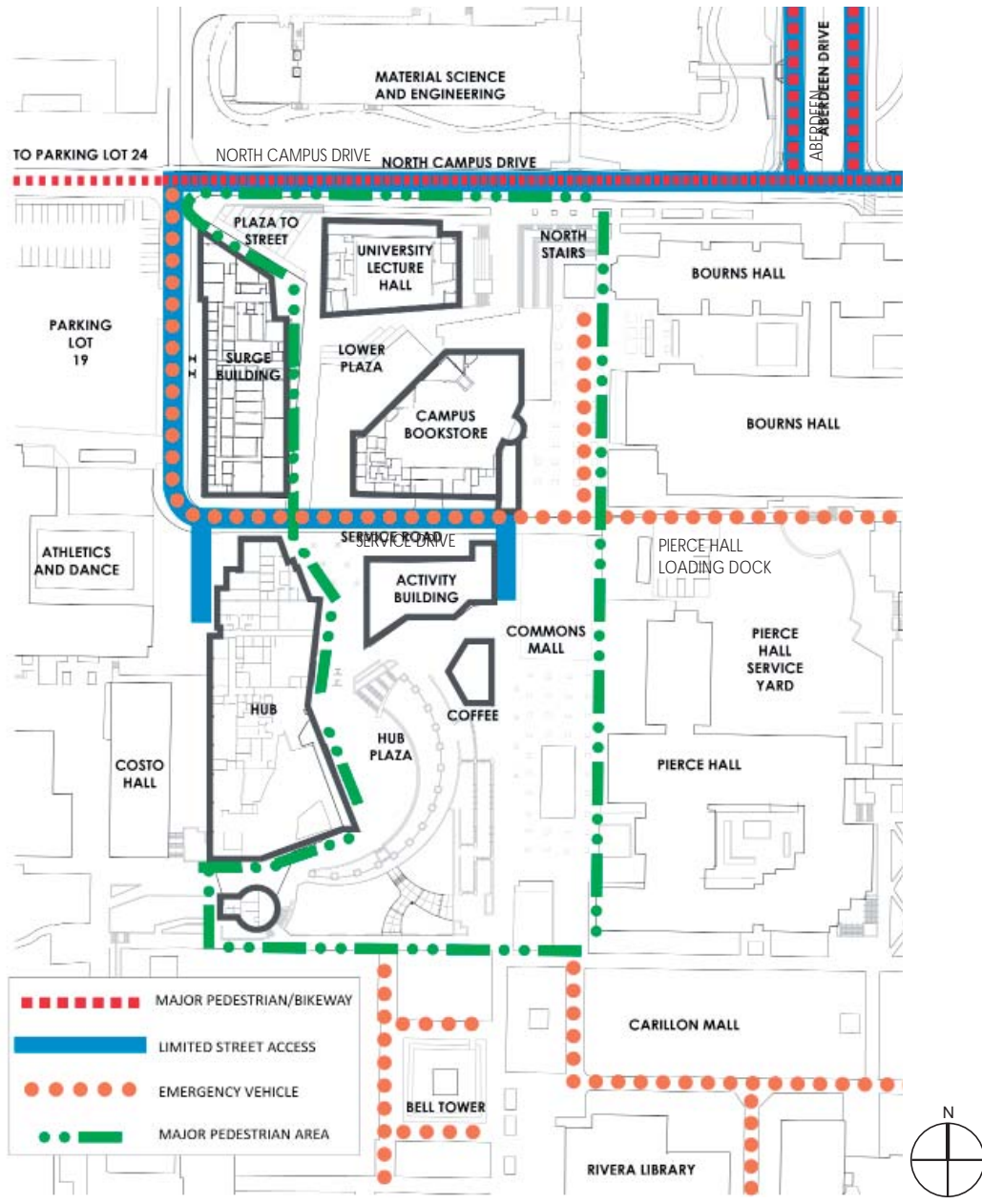

SITE CIRCULATION DIAGRAM



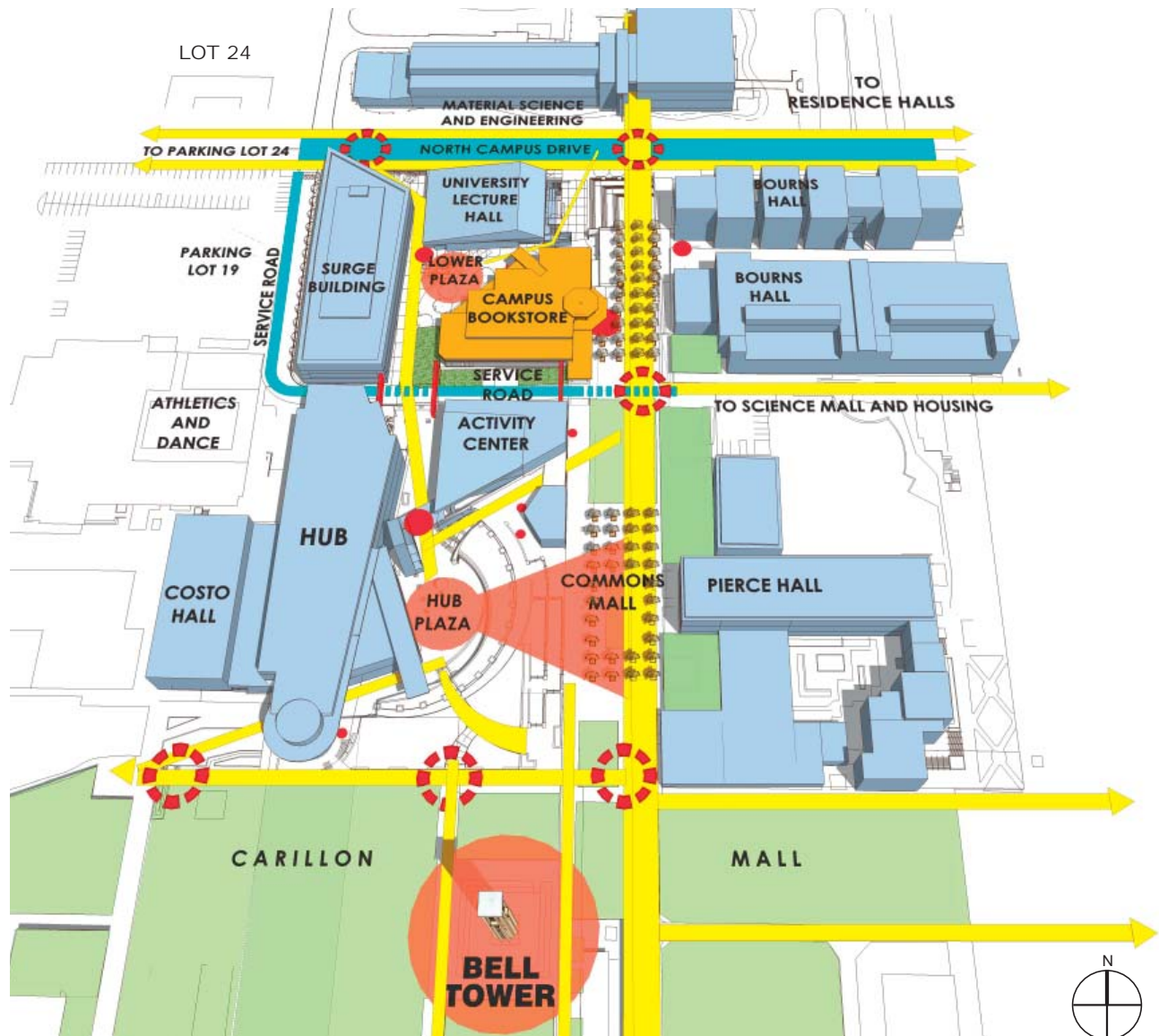

VEHICULAR CIRCULATION

The project site is a pedestrian zone. There are dismount areas for bicycles with bike racks at the perimeter, and fire access is required only along the east side of the Commons Mall adjacent to Bourns Hall. The existing east-west Service Road bisects the project site and will remain in use, requiring service vehicles to be regulated. North Campus Drive provides restricted vehicular access to the Service Road and to the HUB loading dock, with a gate arm located at its intersection with Aberdeen Drive.

The crosswalk between Surge and the Lower Hub will be improved as part of the Parking Lot 19 renovation project, and a sliding gate will be added where the service drive enters the Commons Mall. This gate is to prevent bicyclists and pedestrians from using the delivery zone between buildings, and to prevent non-authorized vehicles from crossing into the mall. The proposal is that only vehicles necessary for the Pierce Hall loading dock and emergency vehicles will be permitted to pass through the gate to the Mall.



SITE CIRCULATION MAP

-  GATEWAYS TO SITE
-  PEDESTRIAN CIRCULATION
-  SERVICE VEHICLES
-  GATHERING SPACES

PEDESTRIAN CIRCULATION

The project site is permeable on all sides, with many pedestrians coming from the east along the edge of Bourns Hall, traveling north through the Commons Mall, or walking up from the below grade HUB Plaza east to the Commons Mall or north to the Lower Plaza. Pedestrians also come

from the northwest, along the walkway from Parking Lot 24, and an increasing number are coming south from the newly opened MS&E Building directly across North Campus Drive; more will follow as future building projects are completed to the north including new Residence Halls.



EXISTING RIVERA LIBRARY ARCADE



UCR CAMPUS-HISTORIC VIEW



UCR CAMPUS-HISTORIC AERIAL VIEW

LANDSCAPE TRADITIONS

UCR began with the UC Citrus Experiment Station established in 1907 and moved to its current site (UCR campus) in 1917. The College of Letters and Sciences opened in 1954. As a land grant college, the campus has always had strong agrarian roots, and landscape selections and design should take clues from the ordering of the citrus groves and inspiration from the plant varieties in the campus Botanic Gardens.

The campus plan was historically organized around a series of open landscaped malls. The most prominent of these is the Carillon Mall-- the site of the campus Bell Tower-- which runs perpendicular to and marks the southern end of the Commons Mall. Each Mall is simple in design but distinct in character, and the Commons Mall should continue to follow this tradition.



COMMONS MALL AT BOOKSTORE ENTRY



COMMONS MALL LOOKING SOUTH



COMMONS MALL LOOKING NORTH

COMMONS MALL

The Commons Mall extends north-south for approximately 700 feet, from the Carillon Mall to North Campus Drive. In recent years, landscape and pathways have been impacted as construction projects demanded staging/lay down areas within the Mall. Edges and open spaces are no longer differentiated, and the Mall has lost its distinctiveness.

Renovations or enhancements must factor in: multiple choices for seating, eating, relaxing, and studying; the need for shade; the importance of established north-south axes; the HUB's introduction of new diagonal axes from the west; sustainable planting selections and preservation of notable mature trees; and upgrades to irrigation. New power and lighting systems should include outlets for laptops and wireless connections.



LOWER BOOKSTORE ENTRY



EASTSIDE WITH SURGE BUILDING ON LEFT



NORTHSIDE WITH LECTURE HALL ON RIGHT

EXISTING LOWER PLAZA

The Lower Plaza-- bordered by the University Lecture Hall, Surge Building, and the Bookstore Building-- is currently undervalued as usable outdoor space. It is now and will become even more of a major pedestrian connection to the lower level of the HUB complex as the Service Road access is restricted, and as more pedestrians come from University Avenue and Canyon Crest Drive or across North Campus Drive from MS&E and residential buildings.

The Lower Plaza must be re-graded to permit new entrances and to lower windows along the Bookstore building's northeast and northwest facades and to provide an accessible path across the existing Service Road crosswalk. Better seating, more shade, improved landscaping, and defined event and circulation space can support campus constituents and visitors using programs in the Bookstore, the Surge Building and the Lecture Hall. [Improvements to the entrance areas and stairs from North Campus Drive are excluded from this project scope but are included in the Vision Plan.]

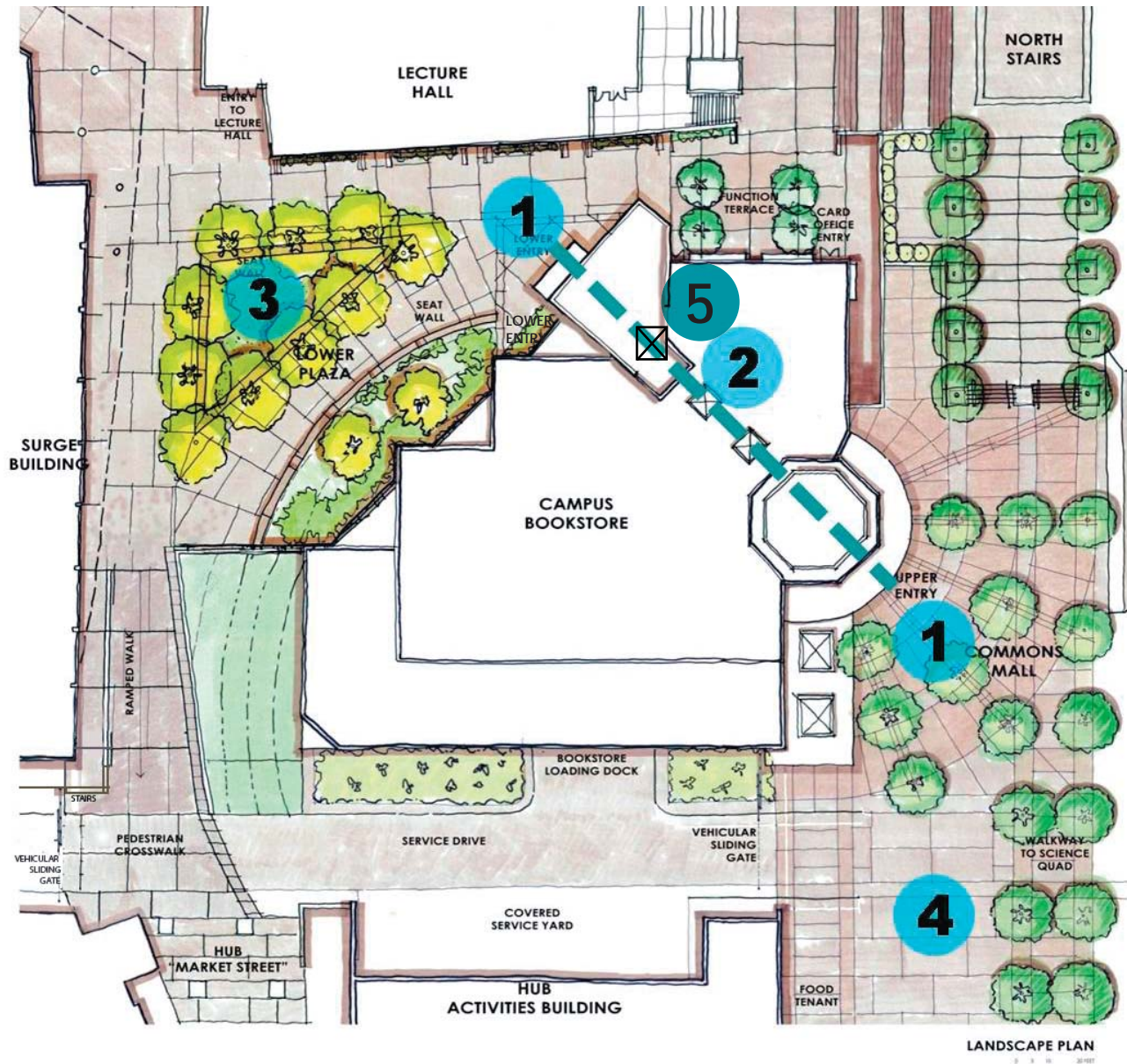

CONCEPTUAL LANDSCAPE PLAN

CIRCULATION AROUND AND THROUGH THE BOOKSTORE BUILDING

The existing two-level building is connected by an existing interior stair (2) which leads from the upper level retail sales floor down to textbooks and the computer store at the lower level. The lower level entrance to the Bookstore(1) has long been closed to provide security for textbook sales, providing no marketing potential or welcoming features to users of the Lower Plaza.

Both upper and lower entrances (1) should be open for cross circulation, encouraging more users and sales activity. A new public elevator near the stairway is also required for accessibility (5). Site improvements (3) and (4) should create direct paths to each entrance.



SOUTH COVERED WALKWAY LEADING TO COMMONS MALL



BOOKSTORE NORTH ELEVATION

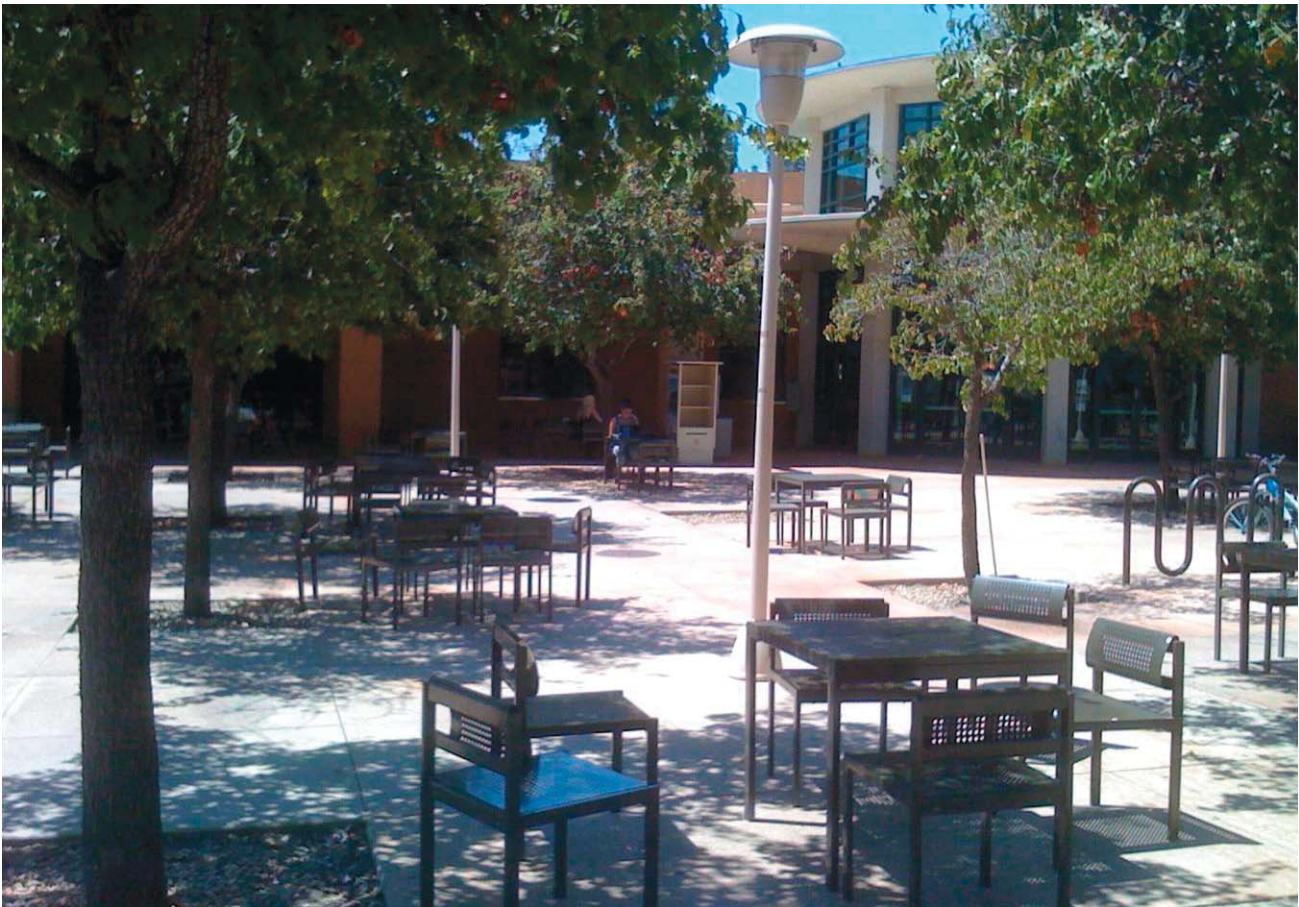

ROTUNDA ENTRANCE - EAST SIDE

EXISTING BUILDING EXTERIOR

The 1991 Bookstore building is largely obscured from view by many trees and a low building canopies along the Commons Mall frontage; high windows and overgrown landscape at the Lower Plaza; and the absence of retail signage.



BOOKSTORE STAIR - TO LOWER LEVEL

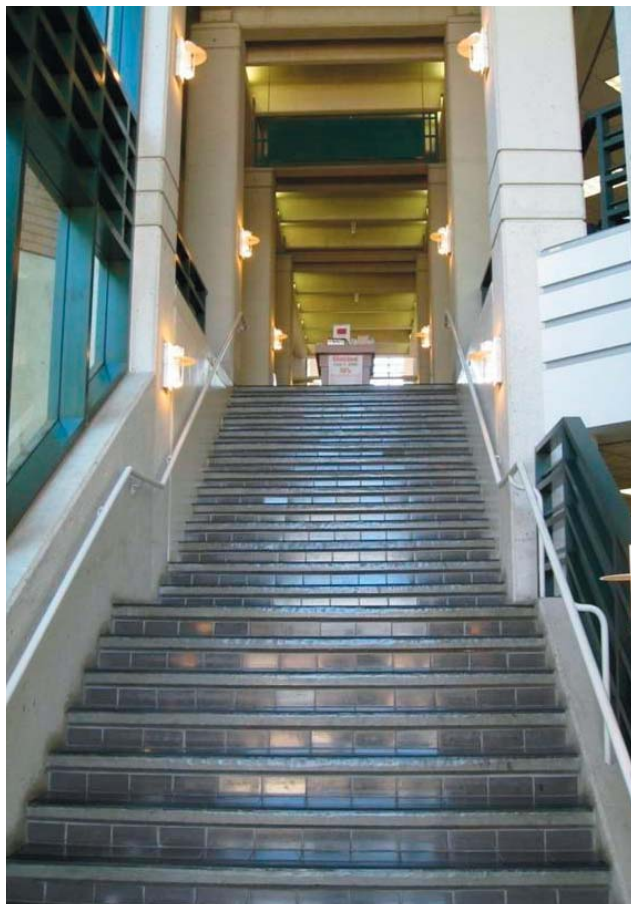

BOOKSTORE STAIR - TO UPPER LEVEL



BOOKSTORE - PASSAGEWAY TO MAIN STAIR

EXISTING BUILDING INTERIOR

Upper floor store interiors lack visibility and strong retail presence. The existing central staircase, when opened to the Lower Plaza, requires upgraded lighting and finishes. Utility upgrades are also required which are described in the Technical Narratives in Section 8.

4. SITE ENHANCEMENTS



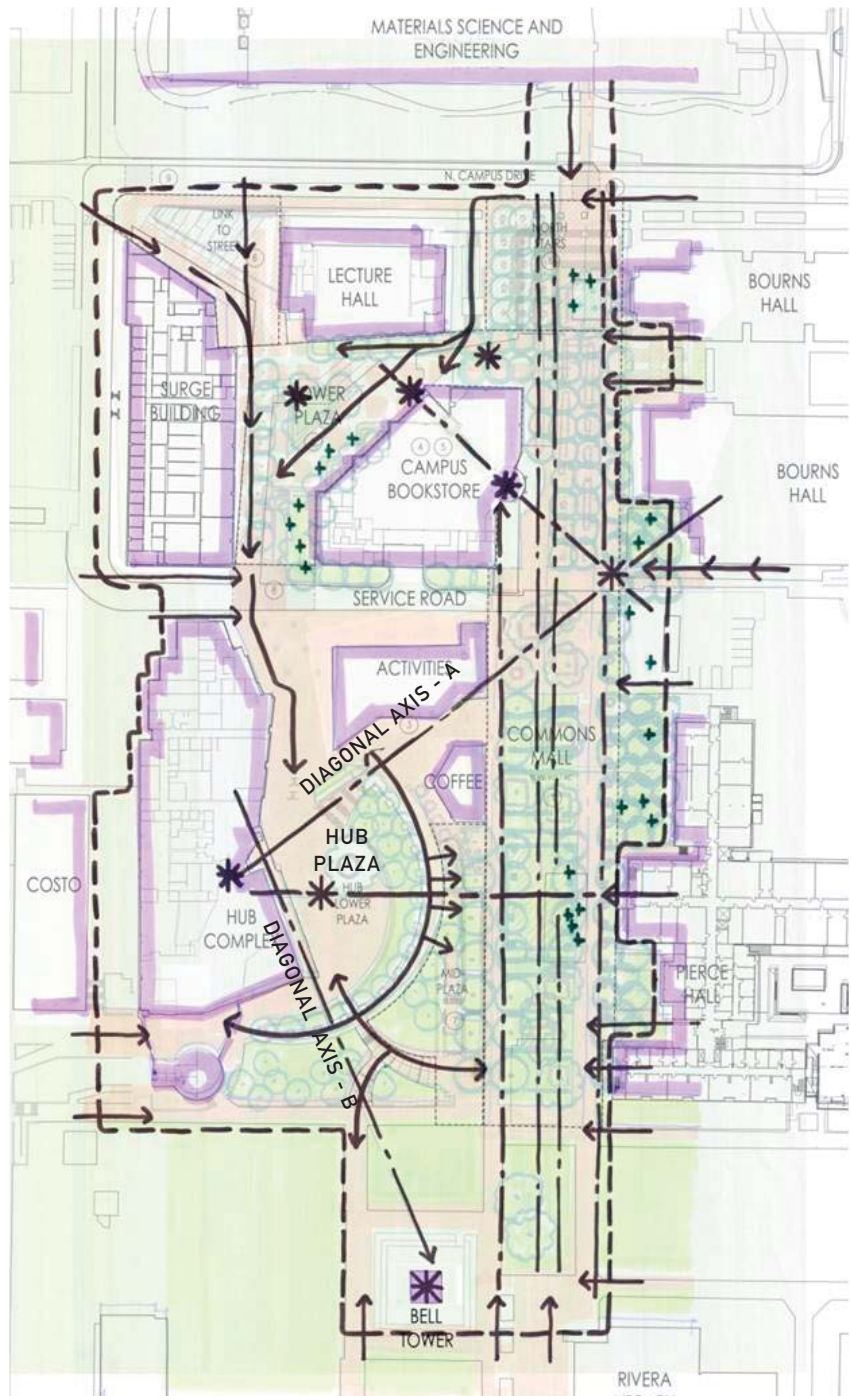

SITE ORGANIZATION

FRAMEWORK

“Desire Lines”, shown in an early concept sketch, allow students to see where they are going and define pathways to uses along the way. Each line has a distinct point of origin, a focused view, and a significant end point. The HUB site plan introduced two strong diagonal “spokes” (illustrated as A and B) which extend from the lower HUB Plaza to engage the Commons Mall.



VIEW FROM HUB LOOKING NORTHEAST

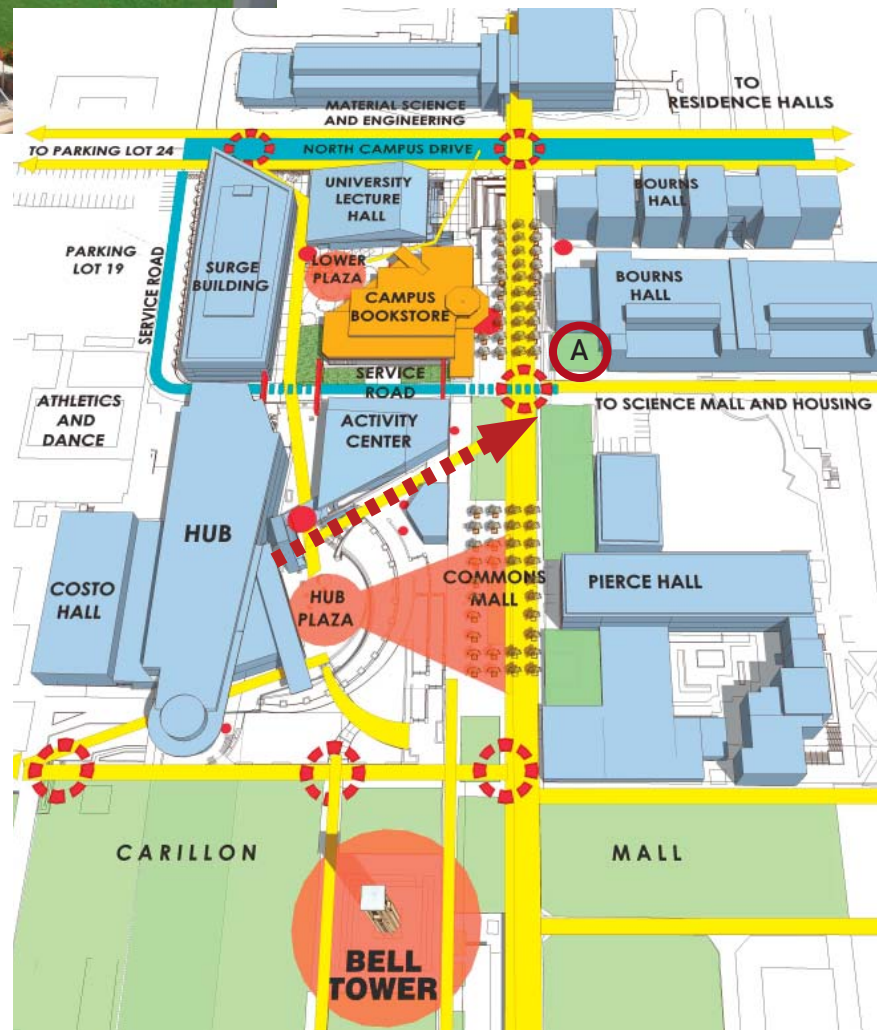

NORTHEAST AXIS

One strong diagonal axis leads northeast from the HUB with views to the mountains. Where this pedestrian walkway meets the path coming west along the side of Bourns Hall, a new small seating court (A) will expand the arrival point and provide desirable resting and watching space.



VIEW FROM HUB LOOKING SOUTHEAST

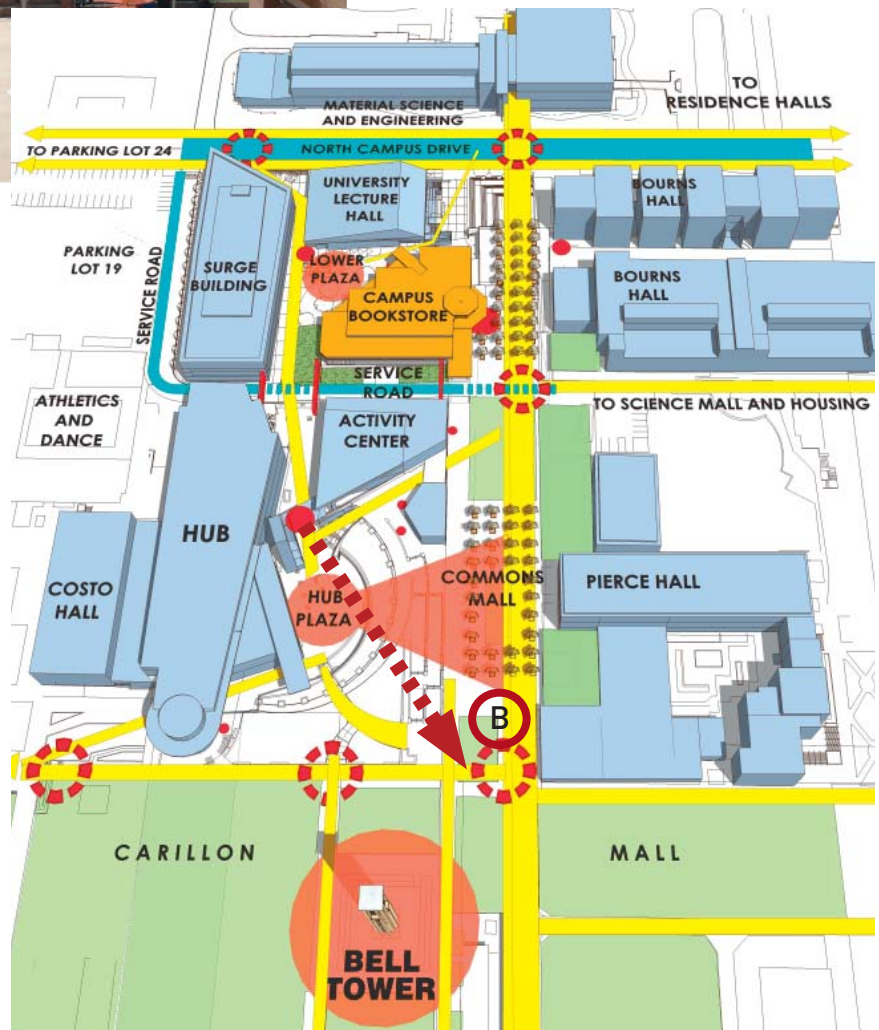

SOUTHEAST AXIS

The second diagonal axis leads southeast from the HUB Plaza, with views of the Bell Tower. It will terminate in the new events (B) hardscape which may be combined with the Carillon Mall to serve multiple entertainment venues (i.e., the popular annual HEAT concert.)

LANDSCAPE FRAMEWORK

Initial diagrams for open space at the Commons Mall showed two organizing concepts which were used to develop the Preferred Plan.

In both options, flexible gathering spaces were proposed, with a choice of benches, seat walls, tables and chairs.



LINEAR ORGANIZATION

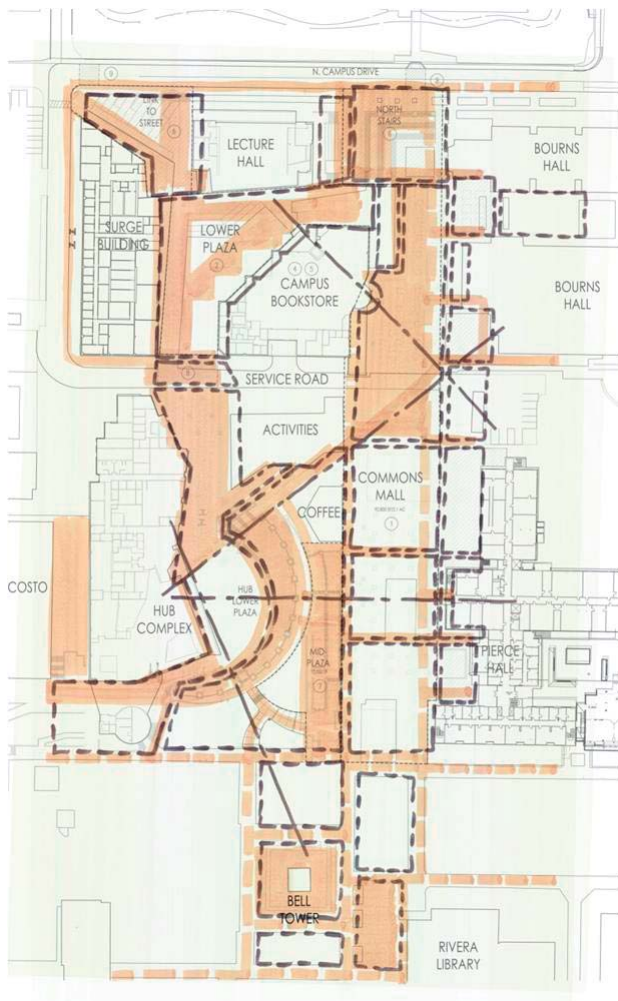

SITE ORGANIZATION



LANDSCAPE

FRAMEWORK ONE: The existing linear north-south circulation is enforced with tree allees along the Commons Mall

4. SITE ENHANCEMENTS



INFORMAL ORGANIZATION

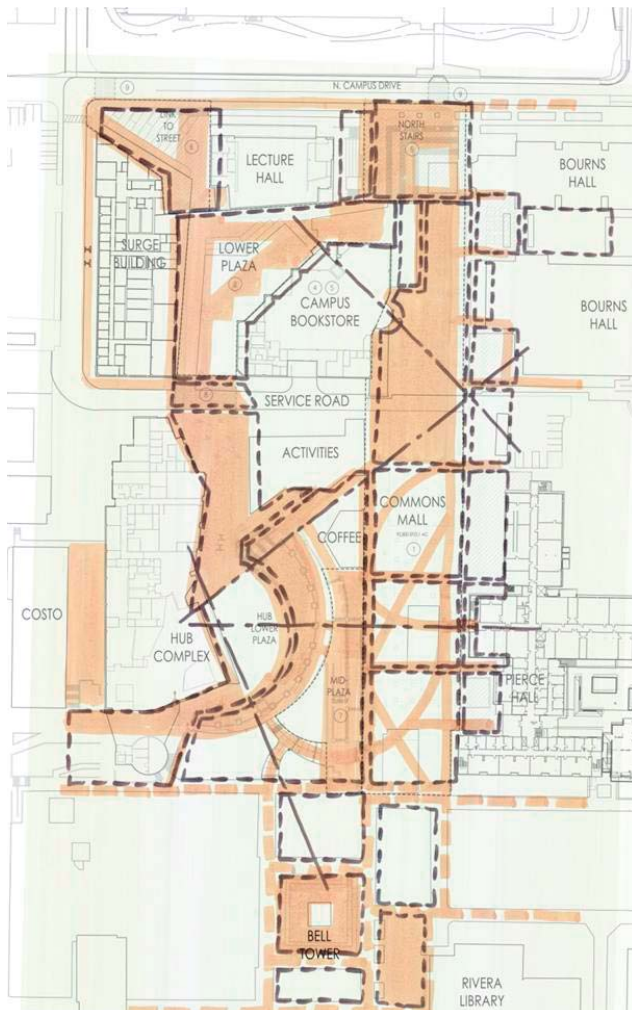

SITE ORGANIZATION

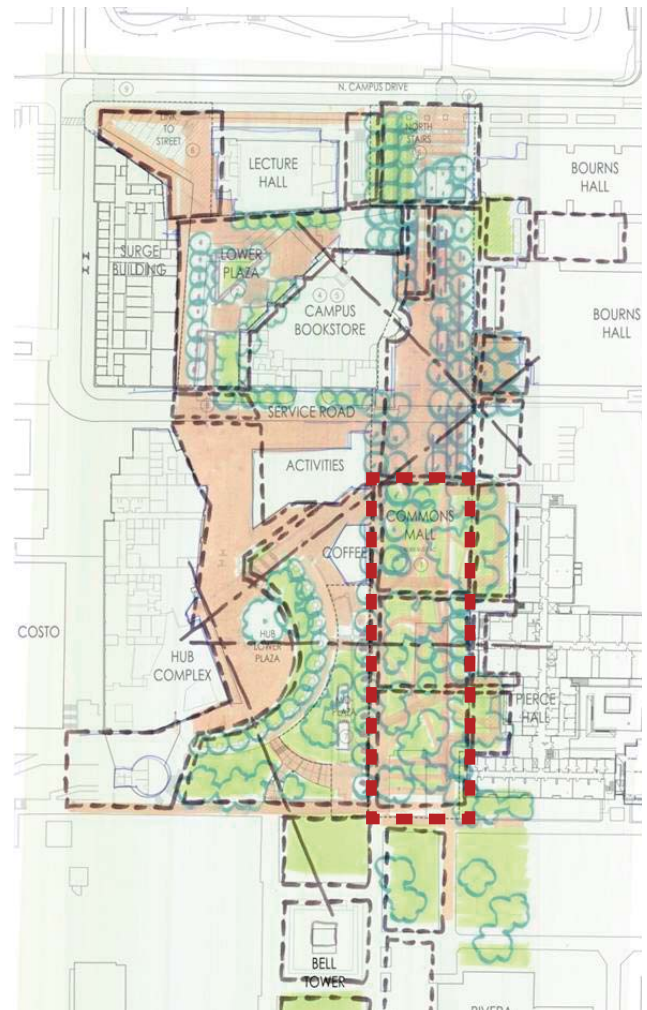

LANDSCAPE

FRAMEWORK TWO: A central campus quad provides non-linear paths and landscape

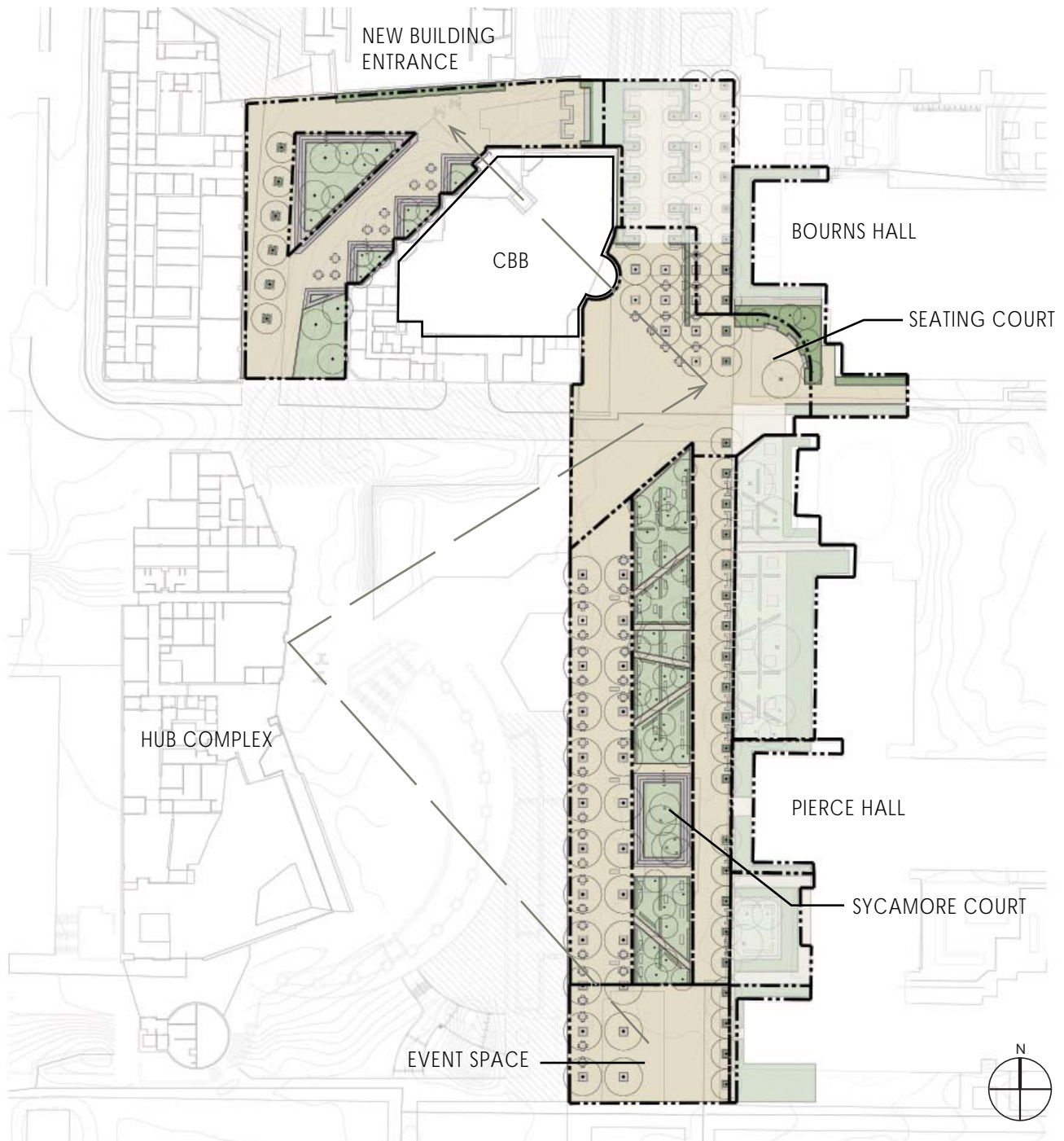

FINAL CONCEPT SKETCH

THE PREFERRED PLAN

The preferred plan took ideas from both Frameworks. Two north-south pathways flank a central landscape core and maintain established circulation routes. A wider walkway serves the west retail edge and accommodates tabling and other student-initiated activities. It is defined by an alley of

shade trees coordinated with existing sign pylons, and ends at the bookstore. A narrower walkway with a single row of trees defines the calmer east edge. In between are a series of landscape zones which will allow for flexible use over time.

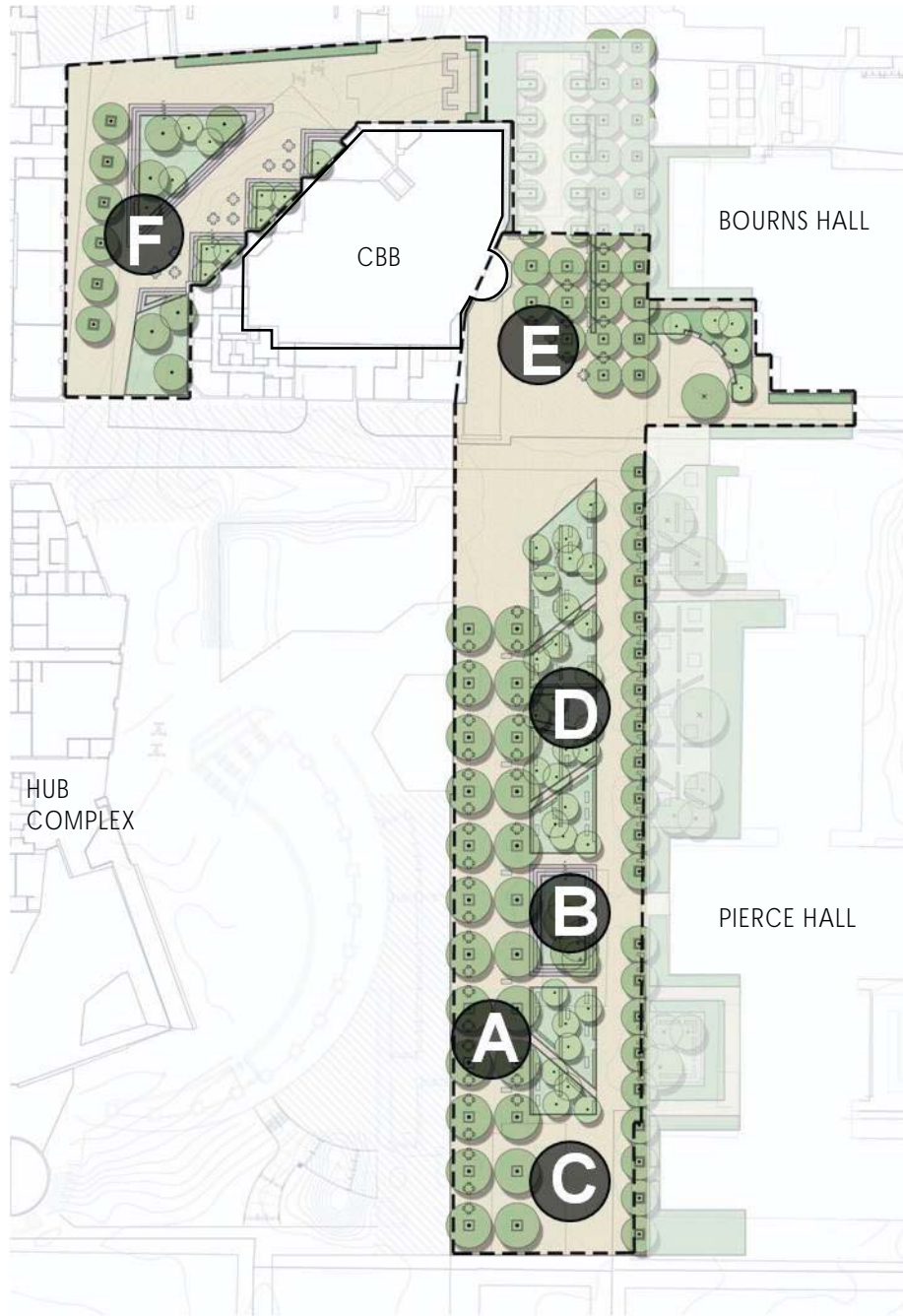

FINAL CONCEPT SKETCH

SPECIAL LANDSCAPE FEATURES

The site design will be organized around special landscape features with distinct plantings, views, uses and experiences. The conceptual design intent for each is described on the following pages.

KEY

- A. NORTH-SOUTH TREE ROWS
- B. SYCAMORE COURT
- C. ENTRY EVENT SPACE
- D. GARDEN COURTS
- E. BOOKSTORE ENTRY PLAZA
- F. LOWER PLAZA

SPECIAL LANDSCAPE FEATURES: (TYPICAL EXAMPLES)



NORTH-SOUTH TREE ROWS: Canopy trees will shade primary north-south pathways and define the west retail edge.



SYCAMORE COURT: Existing mature, heritage sycamore trees will be preserved and celebrated as a central shade garden. A perimeter seat wall will define this space allowing students to engage with all sides of the mall.



ENTRY EVENT SPACE: An expanded hardscape area at the intersection with the Carillon Mall will provide flexible event space for changing uses over time.

SPECIAL LANDSCAPE FEATURES: (TYPICAL EXAMPLES)



GARDEN COURTS: On either side of the Sycamore Court, these landscape spaces will provide additional seating and relaxing space for impromptu use outside of the main circulation zone.



BOOKSTORE ENTRY PLAZA: New landscape and tree locations will cluster seating and direct visitors to the bookstore entrance. The plan also allows for seasonal retail use.



LOWER PLAZA: Seat walls will be designed to define circulation and gathering spaces. The plaza will be re-graded for better access and visibility for tenants, including a prominent entrance to the new elevator lobby and a shared courtyard entrance to the Career Center meeting room and Card Office. New landscaping will include shade trees in seating zones.

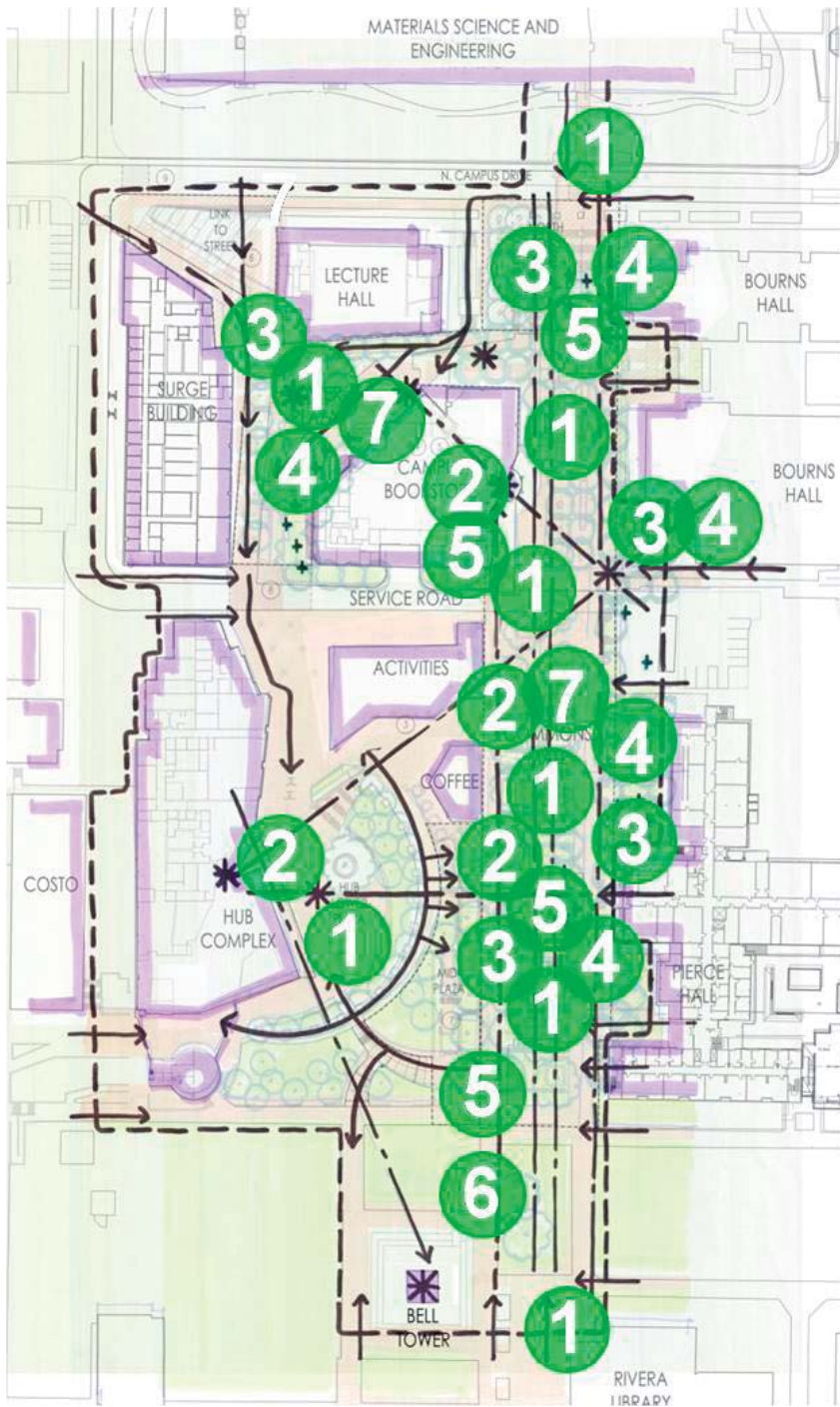

KEY

1. STUDENT INITIATED ACTIVITIES
 - Recruitment
 - Club Activities
 - Annual Events
 - Performances
2. RETAIL
 - Dining
 - Shopping
3. SEATING
 - Tables and Chairs
 - Benches
 - Platforms
 - Seat walls
 - Flex Seating
 - Niches
4. LANDSCAPE
 - Paving
 - Turf
 - Horticultural gardens
 - Canopy trees
5. LIGHTING
6. WAY FINDING
7. SITE AMENITIES
 - Bike racks
 - Recycling
 - Shade structures
 - Art
 - Power outlets
 - Wi-Fi capabilities

AMENITIES

The project site was conceptually programmed for: student-initiated activities; retail uses; expanded seating options; a variety of landscape selections; canopy trees for shade; and site amenities including perimeter bike racks, art and signage wayfinding locations.

4. SITE ENHANCEMENTS

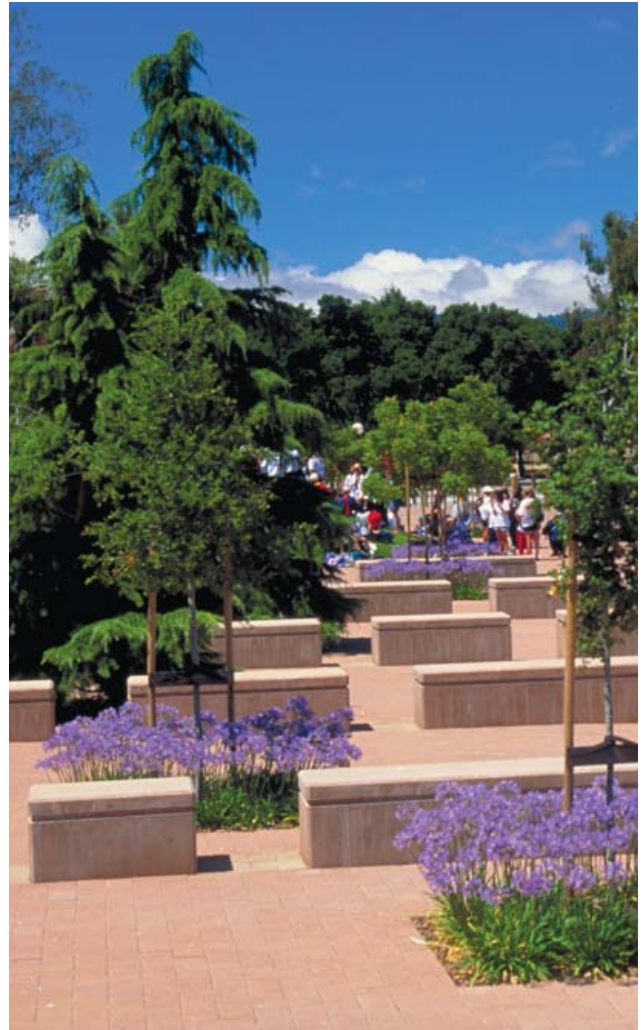

LANDSCAPE AND HARDSCAPE PALETTE

The landscape palette will consist of low water-requiring and climate adaptive plant species that are appropriate for this climate zone, including low maintenance. Trees will be selected to provide shade and a cooling effect and define gathering spaces. Sustainable plantings will be specified, but the Mall will also continue to relate to the established aesthetics of the campus and heavy use as a gathering space

Hardscape selections will be durable and easy to maintain. Traffic-bearing concrete pavers are recommended for the Commons Mall where truck and service traffic will occur.

5. BUILDING IMPROVEMENTS





BOOKSTORE ROTUNDA ENTRY

EXISTING CONDITIONS:

The Bookstore building is a two-story structure built in 1991. The bookstore tenant currently occupies both floors, comprised of an upper level sales floor, staff areas, and loading dock/service area totaling approximately 20,200 GSF; and a lower level with a textbook sales floor, separate computer technology sales floor (COMP UCR), and utility/storage rooms totaling approximately 12,725 GSF. The technical consultants' reviews of the existing building structure and infrastructure are included in Section 8 of this report.



LOWER PLAZA VIEW (CONCEPTUAL)

BUILDING EXTERIOR

LOBBY ADDITION AT LOWER PLAZA AND LOWERED WINDOWS AT CAREER CENTER: A new two-story lobby addition will announce the Career Center and Retail Store. The Lower Plaza will be re-graded and a gas line relocated to allow larger window openings to the Career Center providing increased views and daylight in work and meeting spaces.

CONFERENCE ROOM AND CARD OFFICE ENTRANCES: The Career Center conference room and Card Office will each have a signed exterior entrance to a north courtyard off the Lower Plaza.

SIGN ARMATURES AT UPPER LEVEL: Screens will be designed and installed on existing upper level building facades to support retail signage and strengthen visual connections to the existing HUB complex. Locations include: the south covered walkway entrance, on axis with the Commons Mall signage pylons; the perimeter of the Rotunda roof at the main store entrance; and the northeast building corner visible to the new MS&E building and points north.



NEW COURTYARD AT CARD OFFICE AND CONFERENCE ROOM (CONCEPTUAL)



NEW UPPER LEVEL RETAIL SIGNAGE (CONCEPTUAL)

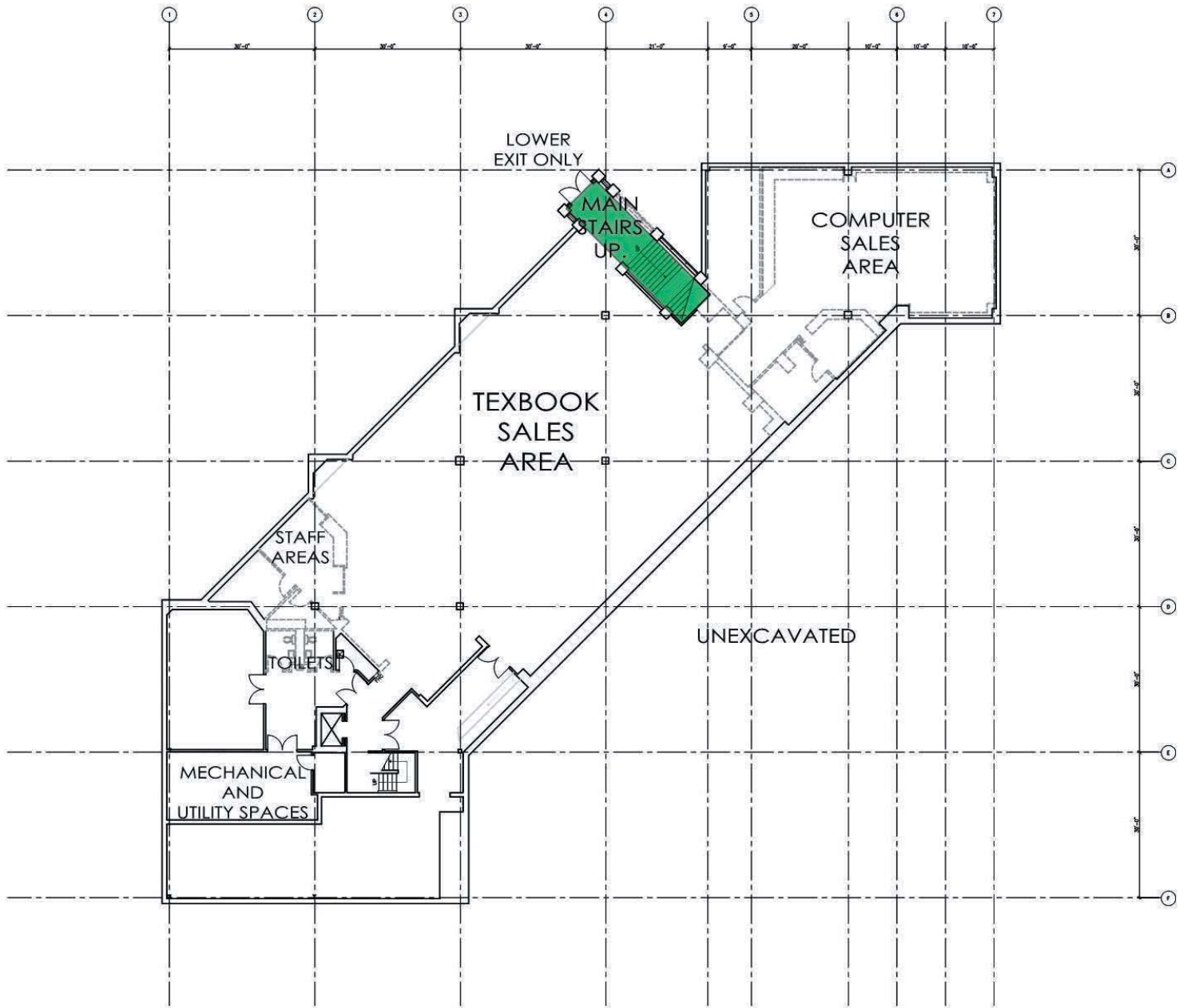

EXISTING LOWER LEVEL



PROPOSED LOWER LEVEL

BUILDING INTERIOR:

LOWER LEVEL: The new 380 GSF lobby will open directly to the Career Center and incorporate the existing central stair leading up to the retail store. A new ADA accessible elevator will be placed next to the stair and will connect the upper and lower floors.

Most of the Lower Level will be repurposed to provide 6,830 ASF for the relocated Career Center which will have a full program of private offices and open workstations, a library for print and computer resources, two small conference

rooms, and a large meeting room with possible use by other university departments after hours.

The relocated Card Office will have 935 ASF and include a customer service area and two private offices. An interior door from the Card Office will provide employee access to a staff lounge and toilet rooms shared with the Career Center. Back of house storage and utility spaces will remain as is, with some needed upgrades to mechanical and electrical equipment.

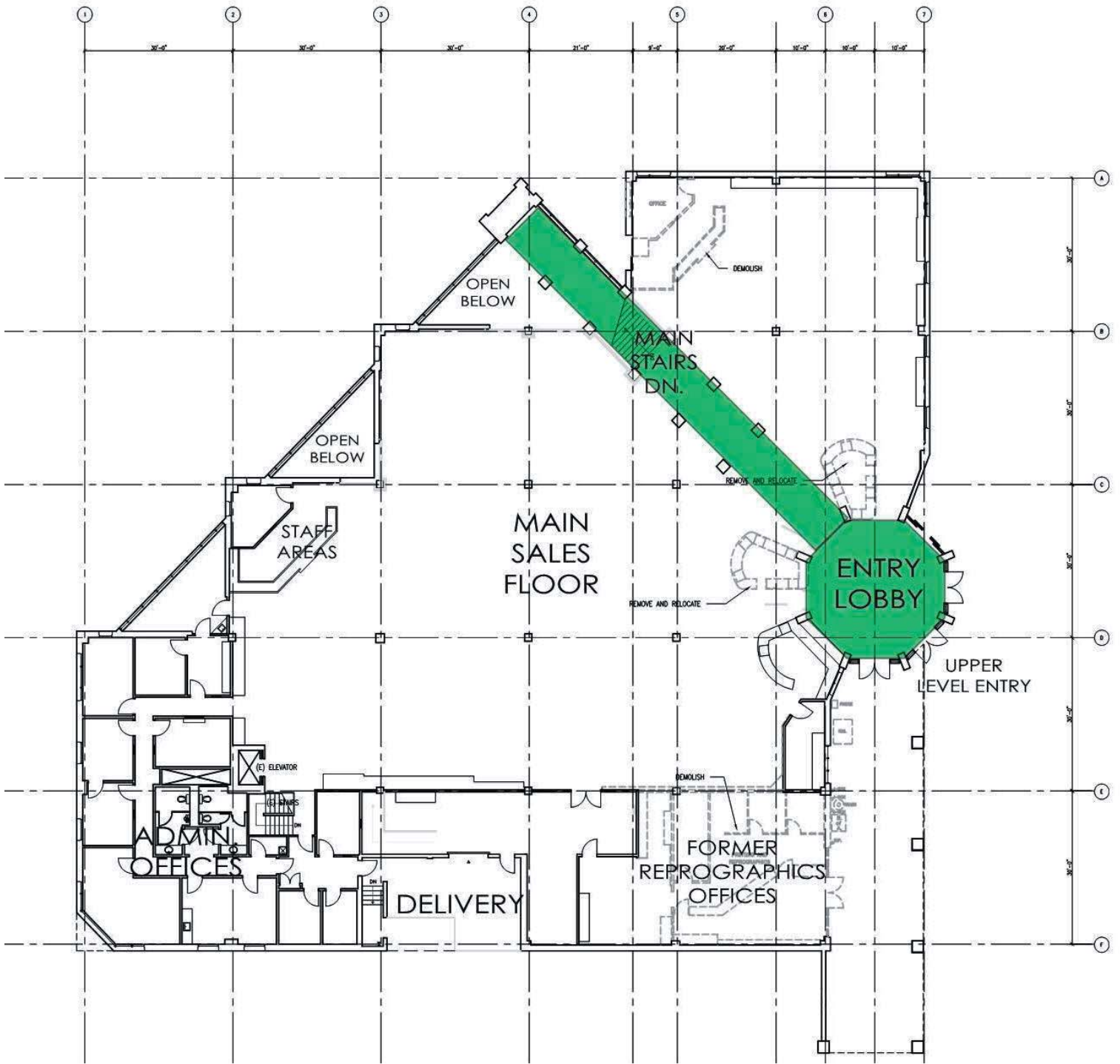

EXISTING UPPER LEVEL

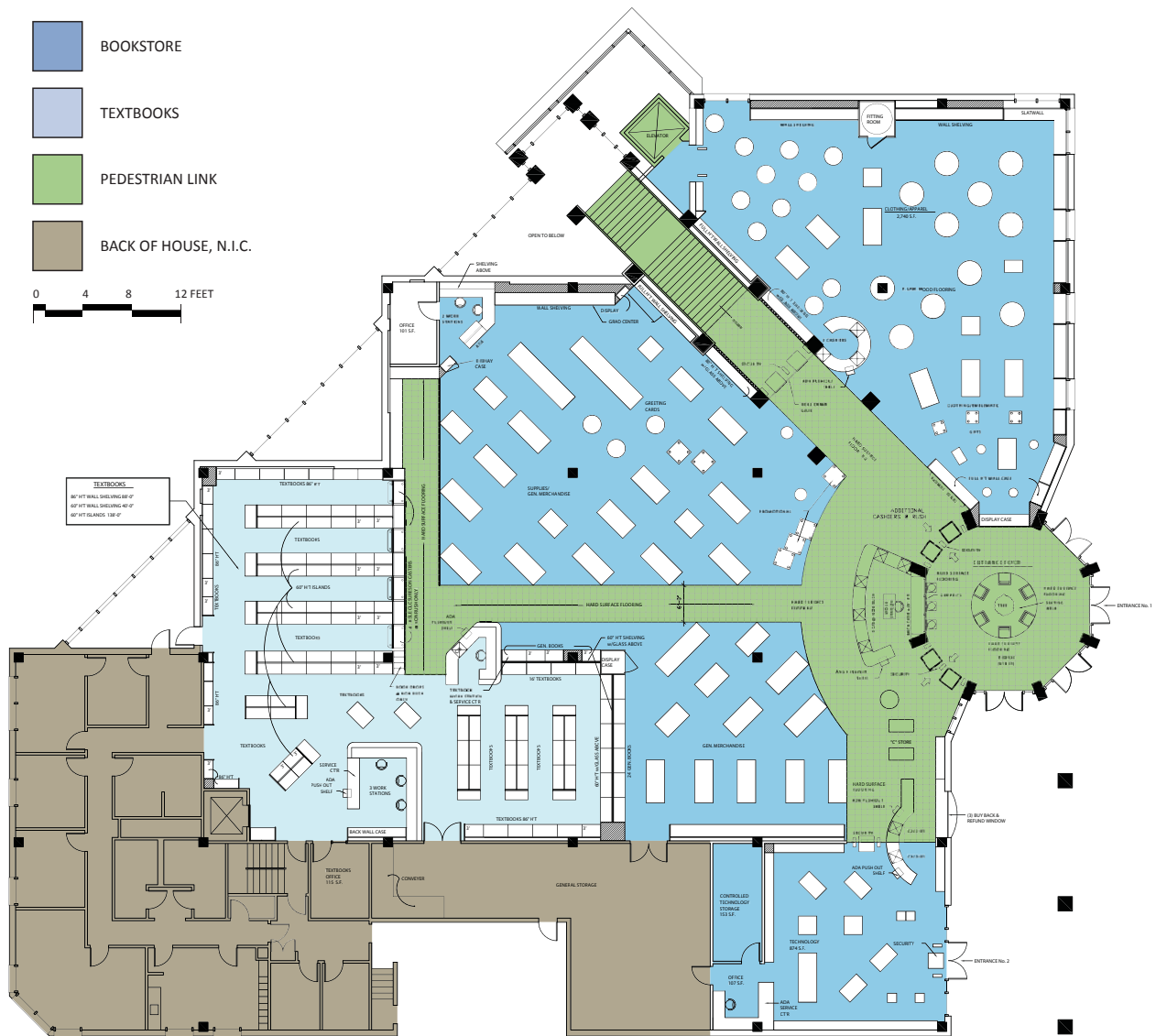

PROPOSED UPPER LEVEL

UPPPER LEVEL: All retail sales will be located on the upper level, reusing some existing shelving and adding new display fixtures, customer service desks, and security access points. COMP UCR will be located at the existing vacant reprographics space closest to HUB retail tenants along the Commons Mall. The renovated sales area will total approximately 12,400 GSF

The upper level rotunda entrance and the existing central stair will be repositioned with new finishes and lighting

to be more welcoming and bolder in appearance; skylights are also proposed over the stair. Existing staff, storage, and receiving areas will remain as is. [The furniture layout shown is conceptual and will be developed during the design phase of work].

The new elevator will be entered entered from the lobby on the first floor and will exit into the north retail area of the second floor.

AREA SUMMARIES:

ROOM SUMMARY-PROGRAMMED SPACES		AREA SUMMARY- ASSIGNABLE SQUARE FEET (ASF)			
Room Name	Room Name/Description	Floor Level	Quantity	Area/Room	Total Area
	CAREER CENTER				
	Reception	1	1	390	390
	Conference Room-1	1	1	175	175
	Library-Resource Area	1	1	450	450
	Conference Room-2	1	1	175	175
	Open Workstations	1	12	80	960
	Private Office	1	9	105	945
	Work Room	1	1	265	265
	Meeting Room	1	1	885	885
	Staff Lounge	1	1	218	218
	Toilets	1	1	360	360
	ASF TOTAL				4,823
	Circ and Service spaces				2,007
	TOTAL CAREER CENTER (ASF)				6,830
	ENTRY LOBBY				
	Entry Lobby	1	1	360	360
	TOTAL ENTRY LOBBY (ASF)				360
	CARD OFFICE				
	Counter and queing	1	1	365	365
	Staff work area	1	1	210	320
	Office 1	1	1	100	100
	Office 2	1	1	100	100
	ASF TOTAL				885
	Circ and Service spaces				50
	TOTAL CARD OFFICE (ASF)				935
	BOOKSTORE				
	Pedestrian Passageway	2	1	560	560
	Main Lobby	2	1	660	660
	Retail Space 1	2	1	8,100	8,100
	Retail Space 2	2	1	2,870	2,870
	Retail Space 3	2	1	1,370	1,370
	Elevator Lobby	2	1	75	75
	TOTAL BOOKSTORE (ASF)				13,635
	Office/Back of House/Services				6,565
	TOTAL GSF PER FLOOR				
	GSF- Level 1				12,725
	GSF- Level 2				20,200
	TOTAL GSF				32,925

5. BUILDING IMPROVEMENTS
AREA DATA SHEET

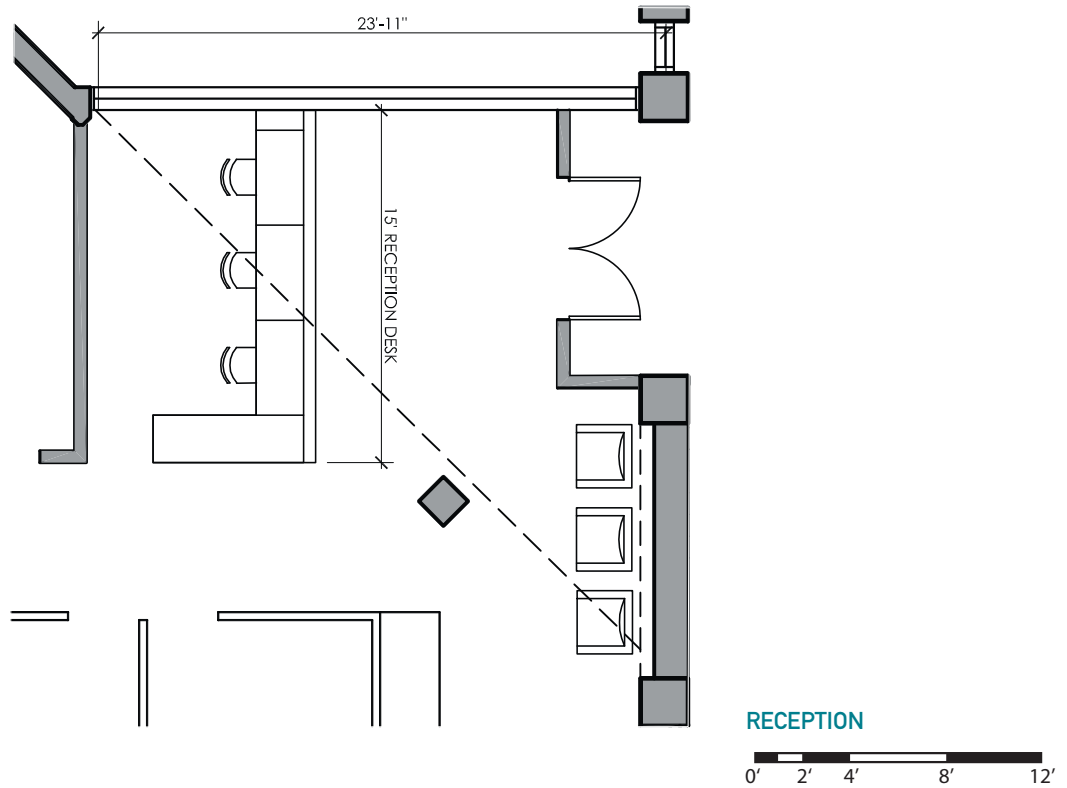

GENERAL INFORMATION

Total ASF	390 ASF
Maximum Number of Occupants	26
Adjacencies	Open Office
Views	To Outside
Minimum Ceiling Height	9'-6"
Accessibility	Per Building Code
Scale	1/8"=1'-0"

BUILDING SYSTEMS REQUIREMENTS

Electrical	Per CEC, Power for Flat Screen TV
Lighting	General Lighting, 30-40 FC
Mechanical	Dedicated Zone
Plumbing	No Special Requirements
Security	None
Fire Protection	Sprinkler, Smoke Detector,
Voice/Data	Phone and Data
Media	Cable connection
Acoustics Measures	Provide Sound Attenuation

MATERIALS AND FINISHES

Ceilings	Acoustical Ceiling Tile
Walls/Base	Low VOC Paint/ Rubber
Floors	Carpet
Windows	Aluminum, Thermal Break
Doors	Aluminum with Glazing
Door Frames	Aluminum with Sidelites

FURNITURE AND EQUIPMENT

Built-In	Built in Reception Desk with Storage Below
Fixed	Window Blinds, Information Display Unit
Movable	3 Lounge Chairs

NOTE: Movable Equipment and Furniture including Media Screens and Projectors are by Career Center. Speakers and Music System not included.

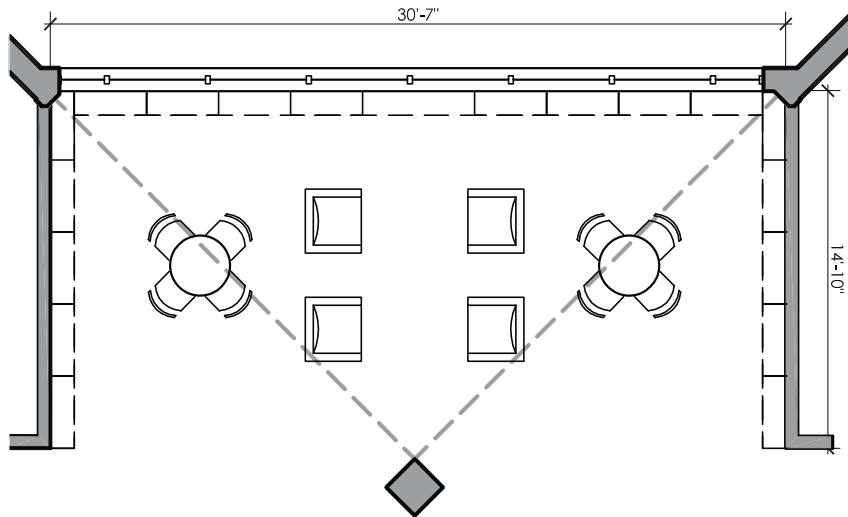

LIBRARY-RESOURCE AREA



GENERAL INFORMATION

Total ASF	450 ASF
Maximum Number of Occupants	9
Adjacencies	Open Office
Views	To Outside
Minimum Ceiling Height	9'-6"
Accessibility	Per Building Code
Scale	1/8"=1'-0"

MATERIALS AND FINISHES

Ceilings	Acoustical Ceiling Tile
Walls/Base	Low VOC Paint/ Rubber
Floors	Carpet
Windows	Aluminum,Thermal Break
Doors	Not Applicable

BUILDING SYSTEMS REQUIREMENTS

Electrical	Per CEC, Power for TV
Lighting	General Lighting, 30-40 FC
Mechanical	Dedicated Zone
Plumbing	No Special Requirements
Security	Not Applicable
Fire Protection	Sprinkler, Smoke Detector,
Voice/Data	Phone and Data
Media	Cable Connection
Acoustics Measures	Provide Sound Attenuation

FURNITURE AND EQUIPMENT

Built-In	Library Shelving
Fixed	Not Applicable
Movable	2 Round Tables, 8 Task Chairs, 4 Lounge Chairs

NOTE: Movable Equipment and Furniture including Media Screens and Projectors are by Career Center. Speakers and Music not included

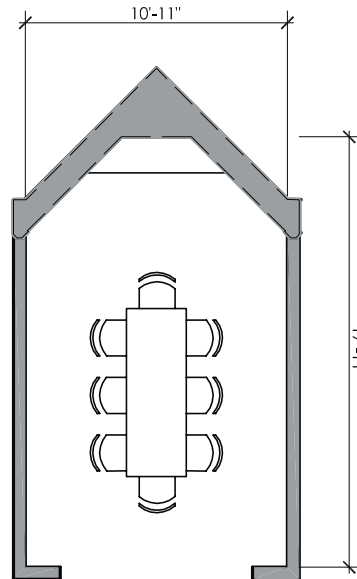

CONFERENCE ROOM 1 AND 2



GENERAL INFORMATION

Total ASF	175 ASF
Maximum Number of Occupants	12
Adjacencies	Open Office
Views	Borrowed Light
Minimum Ceiling Height	9'-6"
Accessibility	Per Building Code
Scale	1/8"=1'-0"

BUILDING SYSTEMS REQUIREMENTS

Electrical	Per CEC
Lighting	General Lighting, 30-40 Fc
Mechanical	Dedicated Zone
Plumbing	No Special Requirements
Security	Not Applicable
Fire Protection	Sprinkler, Smoke Detector,
Voice/Data	Phone and Data
Media	Cable and Speaker
	Connection
Acoustics Measures	Provide Sound Attenuation

MATERIALS AND FINISHES

Ceilings	Acoustical Ceiling Tile
Walls/Base	Low VOC Paint/ Rubber
Floors	Carpet
Windows	Not Applicable
Doors	Not Applicable
Door Frames	Not Applicable

FURNITURE AND EQUIPMENT

Built-In	Credenza with Storage Below
Fixed	2- Whiteboards
Movable	1 Tables, 8 Task Chairs

NOTE: Movable Equipment and Furniture including Media Screens and Projectors are by Career Center. Speakers and Music System not included.

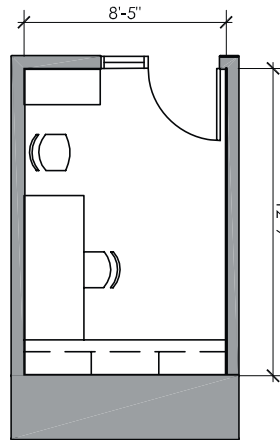

PRIVATE OFFICE



GENERAL INFORMATION

Total ASF	105 ASF
	Card Office 100 ASF
Maximum Number of Occupants	1
Adjacencies	Open Office
Views	Borrowed Light
Minimum Ceiling Height	9'-0"
Accessibility	Per Building Code
Scale	1/8"=1'-0"

BUILDING SYSTEMS REQUIREMENTS

Electrical	Per CEC
Lighting	Indirect/Direct/Task Lighting
Mechanical	No Special Requirements
Plumbing	No Special Requirements
Security	
Fire Protection	Sprinkler, Smoke Detector,
Voice/Data	Phone and Data
Media	No Special Requirements
Acoustics Measures	Provide Sound Attenuation

MATERIALS AND FINISHES

Ceilings	Acoustical Ceiling Tile
Walls/Base	Low VOC Paint/ Rubber
Floors	Carpet
Windows	Sidelite
Doors	Wood-Certified Solid Core
Door Frames	Aluminum with Sidelite

FURNITURE AND EQUIPMENT

Built-In	Not Applicable
Fixed	Blinds At Sidelite
Movable	Task Chair, L-Shaped Desk with Storage, Lateral File, Bookcase, Task Lamp, Side Chair

NOTE: Movable Equipment and Furniture including Media Screens and Projectors are by Career Center. Speakers and Music not included.

5. BUILDING IMPROVEMENTS
AREA DATA SHEET

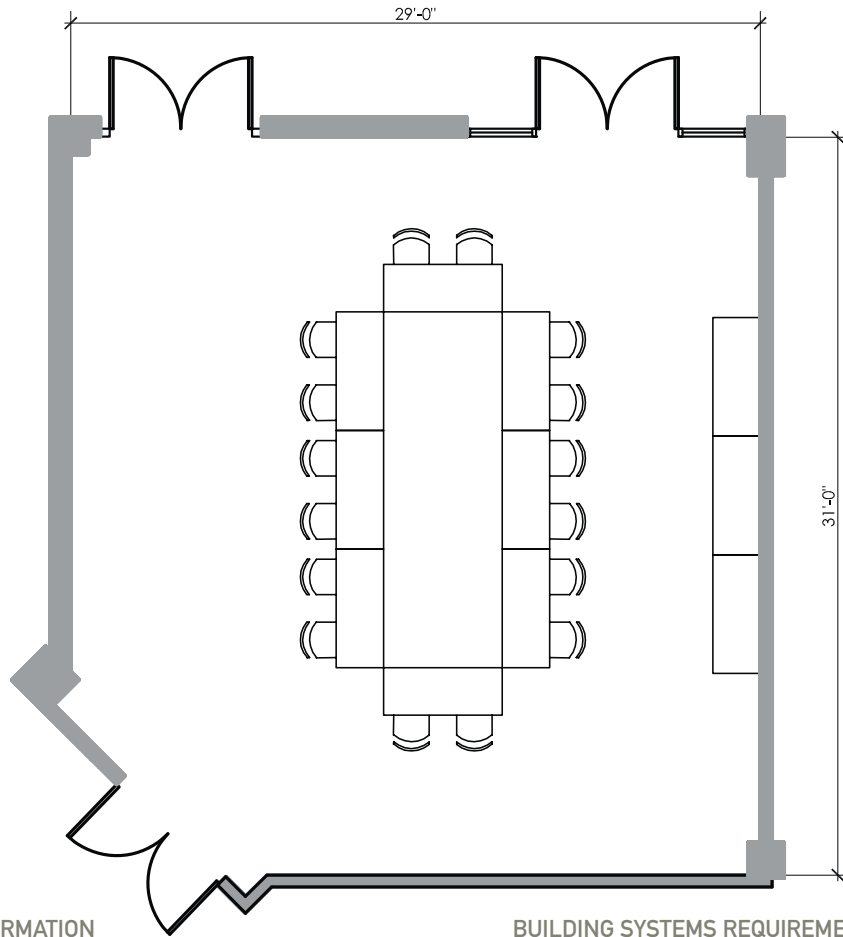

GENERAL INFORMATION

Total ASF	885 ASF
Maximum Number of Occupants	59
Adjacencies	Open Office
Views	To Outside
Minimum Ceiling Height	9'-6"
Accessibility	Per Building Code
Scale	1/8"=1'-0"

MATERIALS AND FINISHES

Ceilings	Acoustical Ceiling Tile
Walls/Base ber	Low VOC Paint/Rub-
Floors	Carpet
Windows	Aluminum, Thermal Break
Exterior Doors	
Interior Doors	Wood-Certified Solid Core
Door Frames	Aluminum with Sidelite

BUILDING SYSTEMS REQUIREMENTS

Electrical	Per CEC
Lighting	General Lighting, 30-40 FC
Mechanical	Dedicated Zone
Plumbing	No Special Requirements
Security	Card Key Access
Fire Protection	Sprinkler, Smoke Detector
Voice/Data	Phone and Data
Media	Cable TV, Roll Down Screen, Ceiling Mounted Projector and Speakers
Acoustics Measures	Provide Sound Attenuation

FURNITURE AND EQUIPMENT

Built-In	Credenza for Catering
Fixed	2- Whiteboards, 4' X 12', Blinds at Window with Blackout Capability
Movable	10 Tables, 20 Task Chairs

NOTE: Movable Equipment and Furniture including Media Screens and Projectors are by Career Center. Speakers and Music not included.

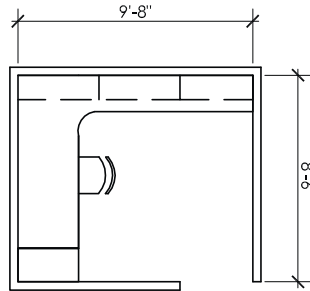

OPEN WORKSTATION



GENERAL INFORMATION

Total ASF	80 ASF
Maximum Number of Occupants	1
Adjacencies	Open Office
Views	To Outside
Minimum Ceiling Height	9'-0"
Accessibility	Per Building Code
Scale	1/8"

MATERIALS AND FINISHES

Ceilings	Acoustical Ceiling Tile
Walls/Base	Not Applicable
Floors	Carpet
Windows	Not Applicable
Doors	Not Applicable
Door Frames	Not Applicable

BUILDING SYSTEMS REQUIREMENTS

Electrical	Per CEC
Lighting	Indirect/Direct/Task Lighting
Mechanical	No Special Requirements
Plumbing	No Special Requirements
Security	
Fire Protection	Sprinkler, Smoke Detector
Voice/Data	Phone and Data
Media	No Special Requirements
Acoustics Measures	Room Sound Attenuation

FURNITURE AND EQUIPMENT

Built-In	Office Workstation
Fixed	
Other	Task Chair

NOTE: Movable Equipment and Furniture including Media Screens and Projectors are by Career Center. Speakers and Music System not included.

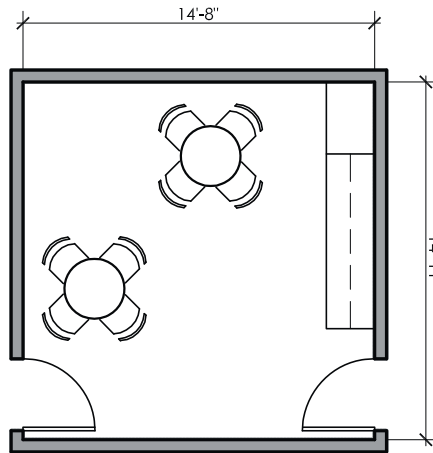

STAFF LOUNGE



GENERAL INFORMATION

Total ASF	218 ASF
Maximum Number of Occupants	15
Adjacencies	Off Main Corridor
Views	None
Minimum Ceiling Height	9'-0"
Accessibility	Per Building Code
Scale	1/8" = 1'-0"

MATERIALS AND FINISHES

Ceilings	Acoustical Ceiling Tile
Walls/Base	Low VOC Paint/ Resilient
Floors	Resilient
Windows	Aluminum, Thermal Break
Doors	Wood-Certified Solid Core
Door Frames	Aluminum Frame

BUILDING SYSTEMS REQUIREMENTS

Electrical	Per CEC
Lighting	General Lighting, 20-30 FC
Mechanical	Exhaust Air
Plumbing	Sink, Dishwasher, Refrigerator
Security	Card Key Access
Fire Protection	Sprinkler, Smoke Detector
Voice/Data	Phone
Media	No Special Requirements
Acoustics Measures	Provide Sound Attenuation

FURNITURE AND EQUIPMENT

Built-In	Kitchen Counter with Cabinets
Fixed	Not Applicable
Movable	Not Applicable
Other	Refrigerator And Microwave, Dishwasher, Trash and Recycling Containers, 2 Tables with 8 Chairs

NOTE: Movable Equipment and Furniture including Media Screens and Projectors are by Career Center. Speakers and Music System not included.

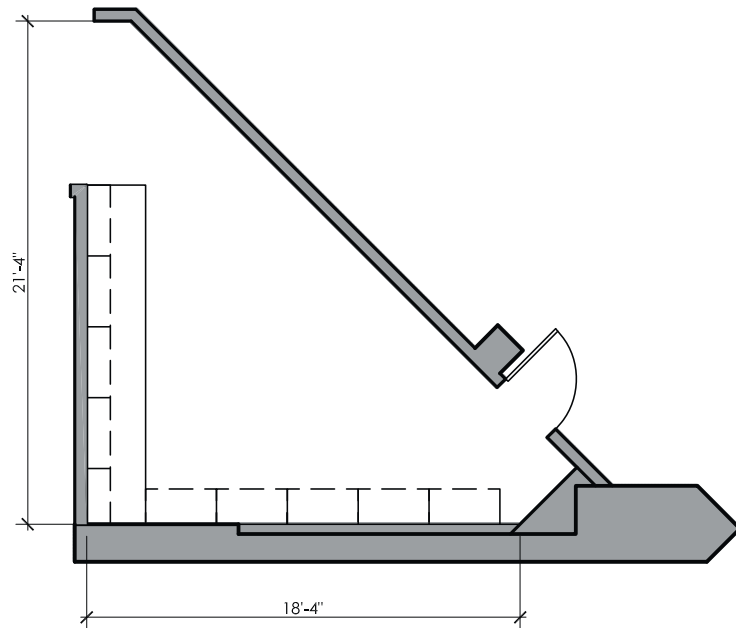

WORK ROOM



GENERAL INFORMATION

Total ASF	265 ASF
Maximum Number of Occupants	2
Adjacencies	Off Main Corridor
Views	None
Minimum Ceiling Height	9'-0"
Accessibility	Per Building Code
Scale	1/8"=1'-0"

MATERIALS AND FINISHES

Ceilings	Acoustical Ceiling Tile
Walls/Base	Low VOC Paint/ Resilient
Floors	Resilient
Windows	Not Applicable
Doors	Wood-Certified Solid Core
Door Frames	Hollow Metal

BUILDING SYSTEMS REQUIREMENTS

Electrical	Per CEC
Lighting	Direct Lighting, 15-20 Fc
Mechanical	Conditioned
Plumbing	No Special Requirements
Security	Card Key Access to Card Office
Fire Protection	Sprinkler, Smoke Detector, Fire Alarm Horn and Strobe
Voice/Data	Phone and Data
Media	No Special Requirements
Acoustics Measures	Provide Sound Attenuation

FURNITURE AND EQUIPMENT

Built-In	18" Deep Shelves, Work Counter with Storage Above
Fixed	Not Applicable
Movable	Not Applicable
Other	Not Applicable

NOTE: Movable Equipment and Furniture including Media Screens and Projectors are by Career Center. Speakers and Music not included.

5. BUILDING IMPROVEMENTS
AREA DATA SHEET

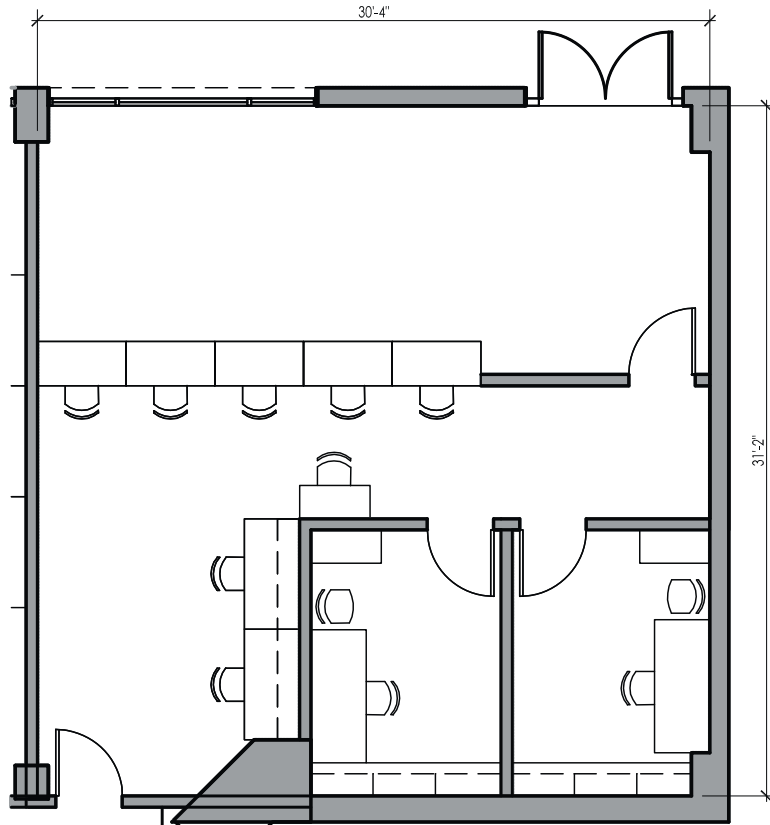

TWO PRIVATE OFFICES:
Refer to Private Office Data Sheet

CARD OFFICE



GENERAL INFORMATION

Total ASF	935 ASF
Maximum Number of Occupants	28
Adjacencies	Off Main Corridor
Views	To Outside
Minimum Ceiling Height	9'-0"
Accessibility	Per Building Code
Scale	1/8"=1'-0"

MATERIALS AND FINISHES

Ceilings	Acoustical Ceiling Tile
Walls/Base	Low VOC Paint/ Rubber
Floors	Carpet
Windows	Aluminum, Thermal Break
Exterior Doors	Aluminum with Glazing
Interior Doors	Wood-Certified Solid Core
Door Frames	Aluminum with Sidelite

BUILDING SYSTEMS REQUIREMENTS

Electrical	Per CEC, Power For Flat Screen TV
Lighting	Direct and Indirect Lighting
Mechanical	No Special Requirements
Plumbing	No Special Requirements
Security	Card Key Access, Security Camera
Fire Protection	Sprinkler, Smoke Detector, Fire Alarm Horn and Strobe
Voice/Data Media	Phone and Data
Acoustics Measures	No Special Requirements Provide Sound Attenuation

FURNITURE AND EQUIPMENT

Built-In	Service Counter- 5 station (one accessible) Counter with Upper Cabinets
Fixed	Flat Screen TV
Movable	2 Task Chairs, 1 Low Table, 4 Lounge Seats, 2 Side Tables
Other	Trash and Recycling Containers

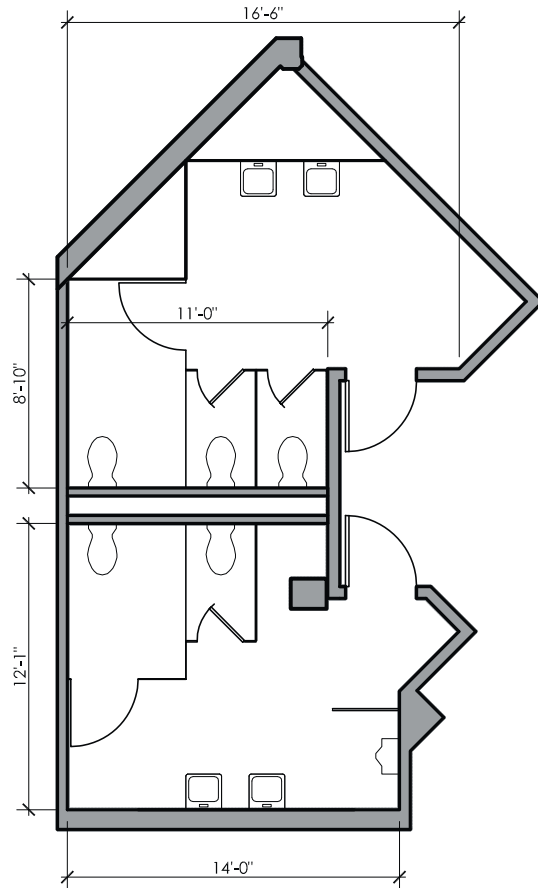

RESTROOMS

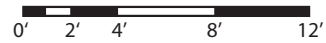

GENERAL INFORMATION

Total SF	360 SF
Maximum Number of Occupants	6
Adjacencies	Off Main Corridor
Views	None
Minimum Ceiling Height	8'-0"
Accessibility	Per Building
Scale	1/8"=1'-0"

MATERIALS AND FINISHES

Ceilings	Low VOC Paint Moisture Resistant GWB
Walls/Base	GWB/Ceramic Tile
Floors	Ceramic Tile
Windows	Not Applicable
Doors	Wood-Certified Solid Core
Door Frames	Hollow Metal

BUILDING SYSTEMS REQUIREMENTS

Electrical	Per CEC
Lighting	Direct Lighting, 30-40 FC
Mechanical	No Special Requirements
Plumbing	Dual Flush Toilets, Flow Control Aerator On Lavatory, Urinal
Security	None
Fire Protection	Sprinkler, Smoke Detector, Fire Alarm Strobe
Voice/Data	Not Applicable
Media	Not Applicable
Acoustics Measures	Provide Sound Attenuation

FURNITURE AND EQUIPMENT

Built-In	Toilet Partitions/Fixtures
Fixed	Not Applicable
Movable	Not Applicable
Other	Not Applicable

6. ENVIRONMENTAL GRAPHICS





INSTALLED HUB GRAPHICS

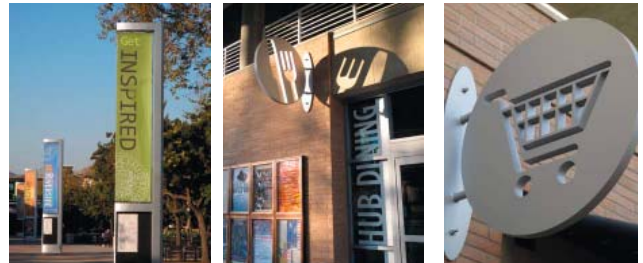

CONTEXT

The HUB graphics program implemented in 2009-10 has provided a memorable identity and name to a place that was previously known as the Student Commons. Notable are the HUB letters wrapping the stair tower and translating the Highlander Union Building into the popular “HUB” gathering place. Similarly, the recently installed aluminum “UCR” letters provide a campus “photo op” with the Bell Tower in the background. These letters have become the preferred symbol for the campus for both visitor snapshots and media coverage because of their flare and instant recognition.

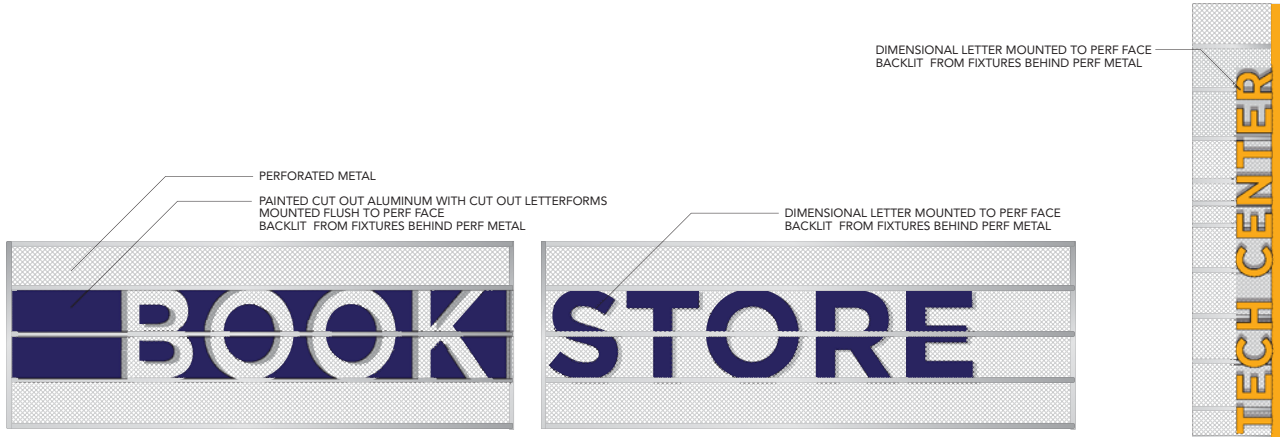

BOOKSTORE ENTRY FROM COMMONS MALL (CONCEPTUAL)

NEW RETAIL STORE SIGNAGE CONCEPTS

Large, colorful lettering at the south store entrance off the Commons Mall will cross the Service Road and link the Bookstore building into the HUB personality. It will become a recognizable terminus to the line of illuminated sign pylons along the west edge of the Commons Mall. Similar signage is proposed to wrap the building's northwest corner.



ROOFTOP SIGNAGE SEEN FROM NORTH CAMPUS DRIVE (CONCEPTUAL)

A raised perimeter screen at the Rotunda roof will allow large rooftop letters to be seen from a distance in many directions.

Surrounded by other buildings, the Bookstore building will also need additional markers at the pedestrian level to define direct pathways to the retail store and Career Center as well as the Card Office.



LOWER BOOKSTORE AND CAREER CENTER ENTRY (CONCEPTUAL)

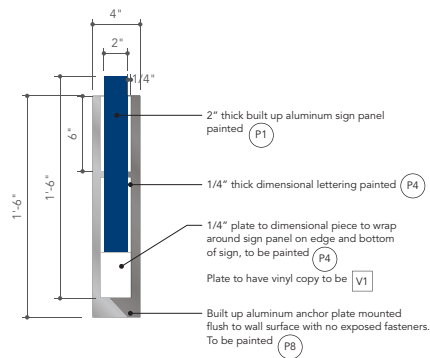
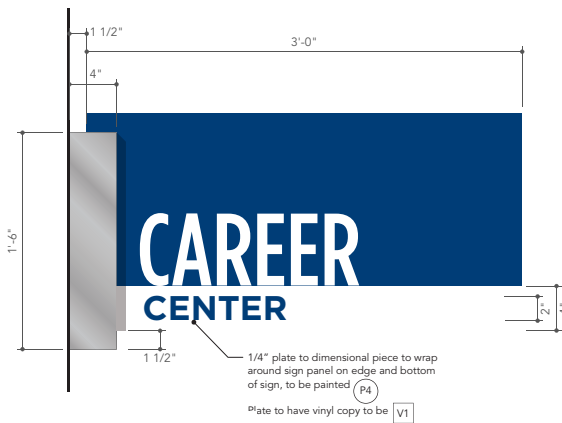
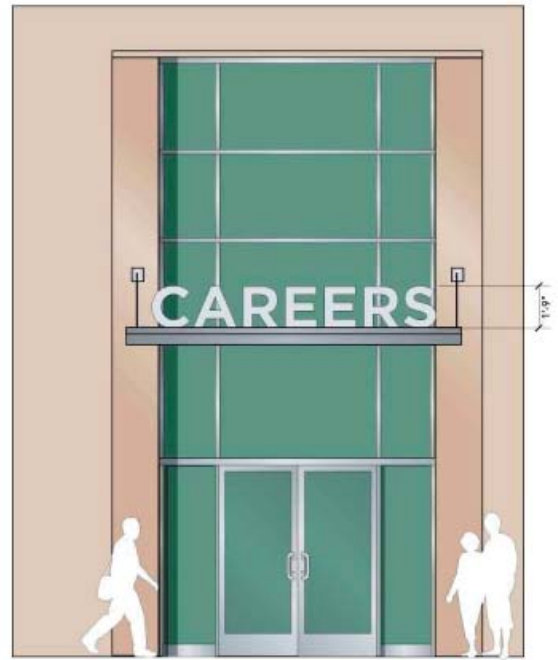

CAREER CENTER AND CARD OFFICE SIGNAGE

Both primary building spaces are entered through the new lobby doors at the Lower Plaza. The building design will include sign armatures and conspicuous locations to name both the Card Office and Career Center.

Concept sign studies illustrate early sign ideas for the shared lobby entrance to the Career Center and upper floor retail store. Entry sign hierarchy will be studied and developed further. Additional sign armatures will be located in conspicuous locations to name all tenants.



EXAMPLES FROM HUB GRAPHICS PROGRAM

WAYFINDING ELEMENTS

The existing HUB graphics program is composed of directional pole signs, tenant blade signs, and large scale wall and window graphics that will be expanded to the Lower Plaza.

Further study will also look at banners along the west pedestrian-only end of North Campus Drive and a new pylon sign marking the northwest entrance to the Lower Plaza. The intent is for signage to be visible from a larger HUB District perimeter.



ENTRY SEEN FROM COMMONS MALL (BEFORE)



ENTRY SEEN FROM COMMONS MALL (CONCEPTUAL)

GRAFFITI PAINTED ONTO BACK WALL



LATITUDE 55 SIGNAGE

The popular student hangout will get a noticeable face lift with new storefront, an extension of the Latitude Mural from the inside out, and a new signboard along the leading edge of the covered walkway. Reader board options shown for this linear sign band are being explored.

7. FUTURE VISION PLAN





FUTURE VISION CONCEPT

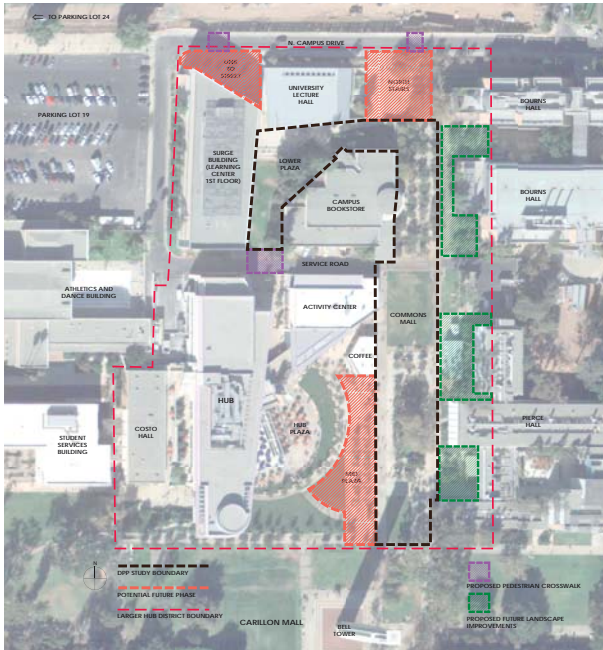

FUTURE VISION PLAN

The perimeter of the DPP project site provides opportunities to expand student uses and to provide wayfinding signage announcing the expanded HUB District.

While these improvements are not part of the DPP scope, the project team took into consideration development of these perimeter edges in a future vision plan. These vision sketches informed the programming process and ensured that future opportunities would not be precluded by the current project.



CONCEPT VISION FOR NORTH STAIRS



NORTH STAIRS TODAY

NORTH: North Campus Drive will be the leading edge of the expanded HUB District.

- The new MS&E Building fronts on this street, and its raised walkway provides direct views to the Commons Mall and Bookstore building.
- Stairs and ramps up to the Commons Mall begin at North Campus Drive.
- Two more pedestrian connections lead around the University Lecture Hall to enter the Lower Plaza and surrounding buildings or continue south to the HUB Plaza.
- Wayfinding signage, kiosks, new landscaping, shade structures and reconfiguration of stair runs are all part of the conceptual Vision Plan.



WEST END OF NORTH CAMPUS DRIVE TODAY

WEST: Students and visitors walking along the pedestrian-only west end of North Campus Drive will arrive at the northwest entrance to the Lower Plaza.

- Signs, pole banners and other site amenities along this established pedestrian walkway can increase awareness of and direct users to HUB services and amenities.
- A prominent signage element at the northwest entrance to the Lower Plaza can be seen from this west end.



CONCEPT VISION FOR SCIENCE COURTS



EXISTING GARDEN COURT AT PIERCE HALL

EAST: Each of the small Garden Courts bordering the academic buildings on the east side of the Commons Mall can be designed as “outdoor rooms” for semi-private and quieter gatherings. These smaller gardens can be accomplished over time with donor contributions such as the annual senior class gift or alumni gifts.

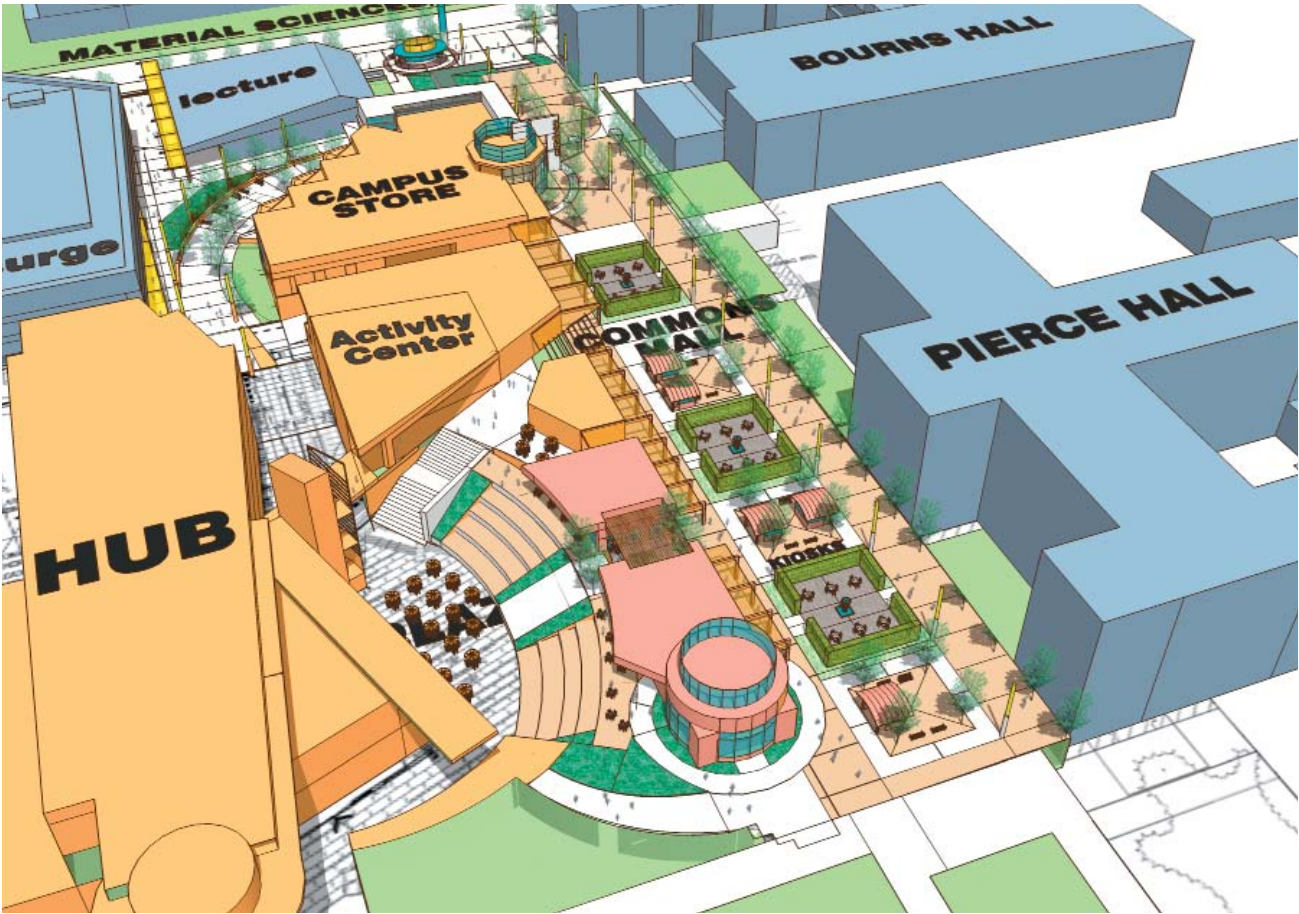

CONCEPT VISION FOR BUILDING ADDITION AT COMMONS MALL



EXISTING LANDSCAPE AT FUTURE BUILDING SITE

SOUTH: The grass area at the southeast corner of the HUB may be considered a future infill building site. Factors to consider include: size and footprint of a new structure, maintaining views to the Bell Tower, building access points, and supporting increased activities anticipated along the Commons Mall. A conceptual building footprint and added shade structures were part of the Vision Plan.

8. SUPPORTING DOCUMENTS



CIVIL DESIGN NARRATIVE

This section establishes Civil Engineering criteria to be integrated in the Detailed Project Program (DPP) for the proposed renovation and enhancement project for the Campus Bookstore and Commons Mall, located on the East Campus of UCR.

The Bookstore is located to the south of North Campus Drive and University Lecture Hall, east of Surge Building, west of Bourns Hall and north of the HUB. The Commons Mall is aligned north-south and is located to the immediate east of the Bookstore. Currently, a Service Road separates the HUB from the Lower Plaza (which is the gathering area by the Surge Building and University Lecture Hall). The Service Road also functions as a fire-access road.

THE GOALS OF THE PROPOSED PROJECT ARE TO:

- Enhance pedestrian access between the upper Commons Mall and the Lower Plaza through the Bookstore interior staircase.
- Provide architectural and landscaping improvements to integrate the Bookstore and Commons Mall with the recently constructed HUB
- Enhance circulation opportunities between the Lower Plaza and the Hub Plaza.
- Relocate the Career Center to the lower floor of the Bookstore, as part of the proposed renovations to the Bookstore.

To increase ease of access between the above referenced spaces, it is intended to build an ADA compliant ramp sloped up at maximum 1:20 (5% equivalent) travelling south from the Lower Plaza to connect to the HUB “Main Street”, south of the Service Road, thus integrating the two zones. A small walk and railing will be needed on the east side of the Surge Facility to work in conjunction with the new ramp and provide access from existing classrooms that currently open to the existing walkway. This new access will be provided with the parking lot improvement project.

To accommodate the Career Center at the lower level of the Bookstore, it is proposed to lower the existing grade at the north of the Bookstore to provide a new plaza at an elevation level with (or slightly higher than) the Lower Plaza. For the purposes of this new configuration, an existing landscaped berm north of the Bookstore will be partially demolished.

Site work improvements for the Commons Mall include demolition of existing concrete pavement and removal of existing understory planting and trees per conceptual DPP Landscape Drawings. Existing concrete pavement is anticipated to be replaced with pre-cast concrete unit pavers and new planting will be provided. Please refer to Landscape Drawings and Narrative for details.

For the purposes of this narrative, two site work options were analyzed and are discussed below.

OPTION 1: Improve circulation opportunities between the Lower Plaza and the HUB “Main Street” by providing an elevated crosswalk and sloped walkway. The existing grade north of the Bookstore will be maintained and the landscaped berm will be protected in place. Improvements for the Commons Mall include replacing the pavement with pre-cast concrete unit pavers and providing new landscaping features. It is also proposed to lower the existing grade at the north end of zones A and D, where currently a landscaped berm is located 16 inches above the adjacent grade.

OPTION 2 (PREFERRED OPTION): In addition to the improvements stated under Option 1, Option 2 includes lowering of existing grade at the north of the Bookstore to provide a new plaza at an elevation level with (or slightly higher than) the Lower Plaza. For the purposes of this new configuration, the existing landscaped berm northwest of the Bookstore will be demolished partially.

Therefore, to facilitate development of a feasible design program for the above referenced options, this section includes a description of existing utilities that are located in the vicinity of the area of study; provide an analysis of those utilities that may be potentially impacted by the above mentioned proposed improvements including possible relocation options and approximate extents of relocation. Please see attached utility exhibits ¹ for reference.

1. Please note the exhibits have been put together based on a compilation of existing UCR as-built/record drawings provided by the Architect, conversations with UCR Physical Plant staff and construction documents of the HUB and Surge Building.

C1.0 GRADING AND STORM DRAINAGE

EXISTING CONDITIONS:

A 15-inch storm drain pipe runs south to north underneath the Commons Mall at an approximate depth of 7 feet at the north end of the HUB Complex and at a depth of 10-feet to the east of the Bookstore. The 15-inch storm drain pipe connects to an arterial storm drain pipe located within the street limits of North Campus Drive. Surface runoff from the Commons Mall is intercepted by area drains located in the concrete pavement.

Roof drain loading from the Bookstore is discharged to a 6-inch storm drain pipe located in the Lower Plaza. Surface run-off from the Lower Plaza is intercepted by area drains along the edge of the landscaped berm and conveyed to the 6-inch storm drain pipe which is located approximately 3 feet below grade. The 6-inch storm drain pipe is upsized to an 18-inch storm drain pipe and carries roof runoff loads from University Lecture Hall and Surge Building. The 18-inch storm drain pipe is located approximately 8-feet to 9-feet below grade. Within the Service Road to the south of the Bookstore, a 12-inch storm drain pipe is located approximately 6-feet to 8-feet below grade.

It is our assumption that existing drainage for the Lower Plaza and Commons Mall is adequately conveyed by the drains and stormwater piping to the arterial storm drainage system located in North Campus Drive.

OPTIONS 1 AND 2:

To accommodate the ramp and staircase to the west of the landscaped berm (as existing along the west face of the Bookstore), some existing area drains located in the Lower Plaza and portions of the 6-inch pipe may need to be demolished. New area drains or trench drains to capture runoff from the ramp and the new plaza will be required.

We anticipate that Common Mall landscaping improvements will require 10-15% of re-grading efforts with new drainage. Based on the available ground cover over the existing 15-inch main pipe and its laterals located in the Commons Mall, the storm drain is not anticipated to be impacted by work in this area and may be protected-in-place.

Rainfall runoff for the proposed improvements in the Lower Plaza and Commons Mall will be conveyed by a non-erosive storm drain system consisting of trench drains, planter drains and area drains, all of which will connect to the existing underground site storm drain piping which we assume is sufficient to support the proposed improvements.

Impacts to the 12-inch storm drain pipe are not expected for the proposed work within the limits of the Service Road and the pipe can be protected in place.

Refer to figures C1.0 and C1.1 for stormwater drainage distribution system.

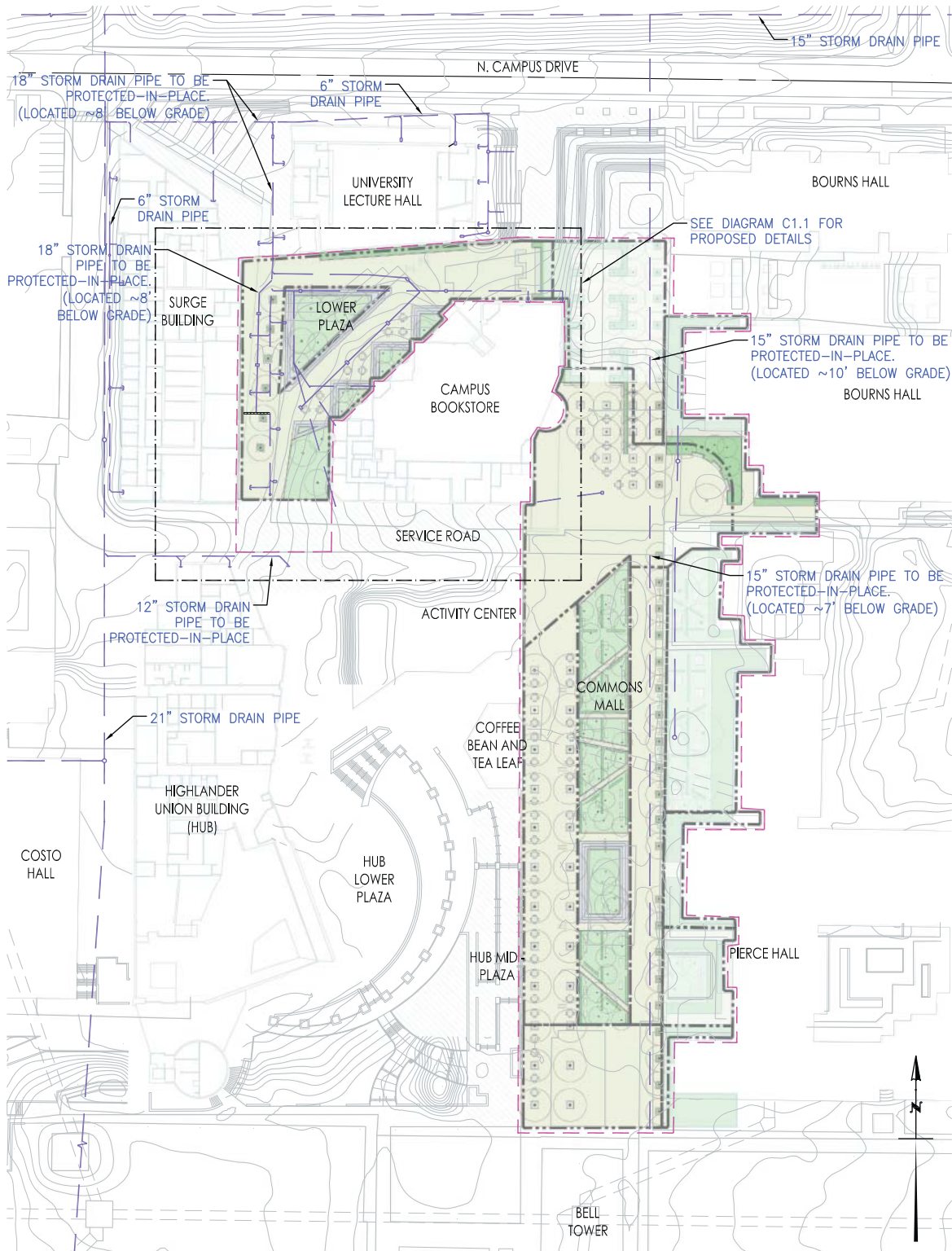

C1.0 STORMWATER DRAINAGE DISTRIBUTION SYSTEM

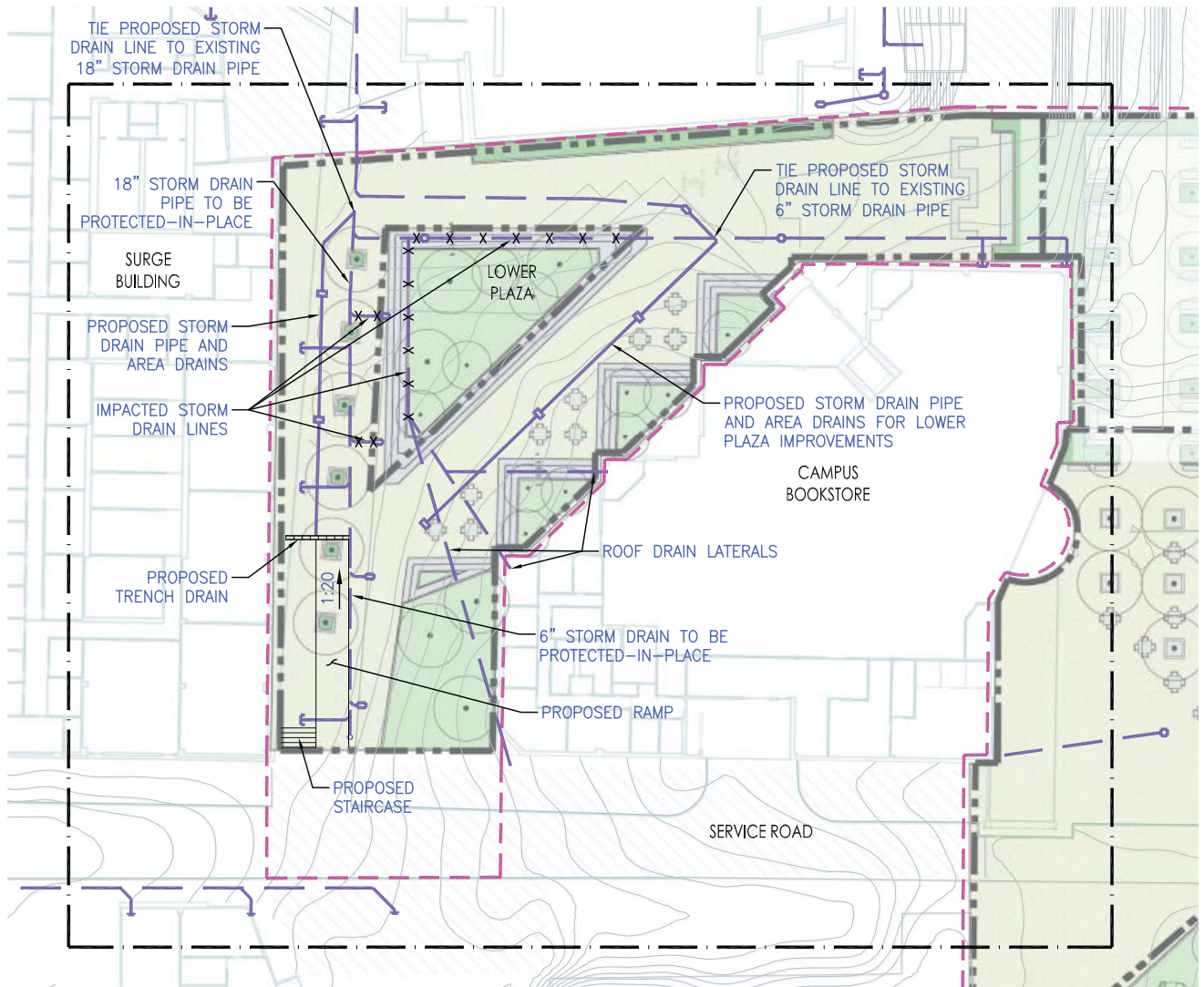

LEGEND:

	SITE IMPROVEMENTS BOUNDARY
	EXISTING STORM DRAIN PIPE
	PROPOSED STORM DRAIN PIPE
	EXISTING SEWER PIPE
	EXISTING WATER PIPE
	EXISTING FIRE WATER LINE
	EXISTING CHILLED WATER LINE
	EXISTING IRRIGATION WATER LINE
	EXISTING ELECTRICAL SYSTEM
	EXISTING GAS LINE
	PROPOSED GAS LINE
	EXISTING UTILITY TUNNEL
	EXISTING CABLE SYSTEM
	TO BE DEMOLISHED

C1.1 STORMWATER DRAINAGE DISTRIBUTION SYSTEM



C2.0 SANITARY SEWER

EXISTING CONDITIONS:

Sewer loading from the Bookstore is discharged to an existing main 8-inch sanitary sewer pipe, which is aligned in south-north direction and located to the east of the Bookstore within the footprint of the Commons Mall.

Per existing as-built plans, it is our understanding that the 8-inch pipe is located approximately 23-feet below grade, as measured from the Commons Mall. At the Lower Plaza level, north of the Bookstore, sanitary sewer pipe laterals exiting the building are approximately 14-feet below grade as measured from the flat landing area in front of the landscaped berm and connect to the 8-inch sewer pipe. The 8-inch pipe connects to a 16-inch arterial sanitary sewer line located within the street limits of North Campus Drive.

Within the Service Road limits of improvement, an 8-inch sanitary sewer pipe servicing the HUB Complex is located approximately 5-feet below the pavement.

OPTIONS 1 AND 2:

The scope of work within the Service Road is to raise the grade to provide an elevated crosswalk connecting the Lower Plaza and the HUB “Main Street”; therefore the 8-inch sewer line is not anticipated to be impacted and may be protected-in-place.

Based on the available ground cover over the existing 8-inch main pipe and its laterals located in the Lower Plaza, the sanitary sewer pipe is not anticipated to be impacted and may be protected-in-place.

Refer to figure C2.0 for sanitary sewer system diagram.

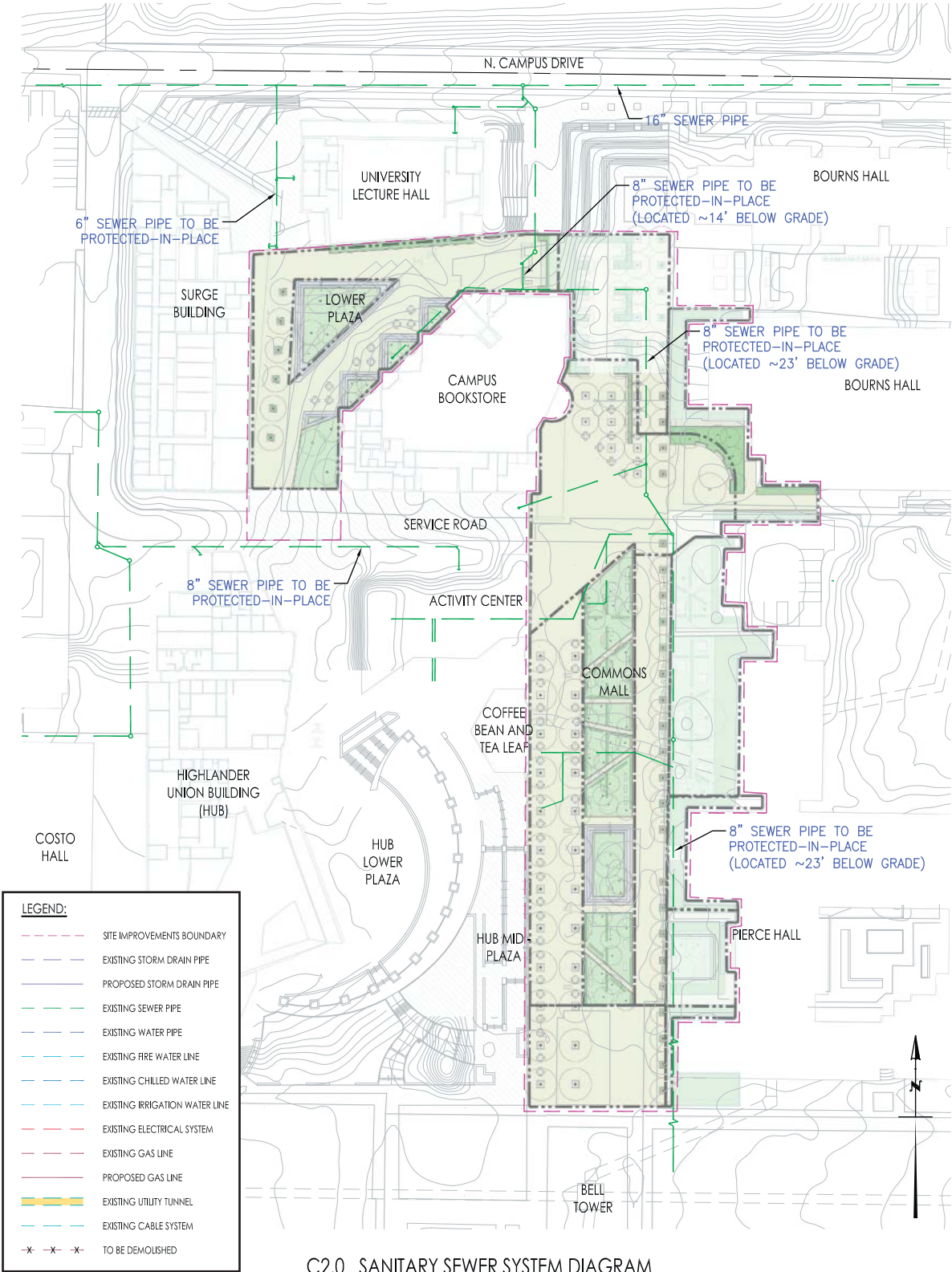

C3.0 WATER – DOMESTIC, FIRE, IRRIGATION, CHILLED WATER

EXISTING CONDITIONS:

20-inch and 4-inch chilled water supply and return pipes, and an 8-inch water main are located within the Service Road, south of the Bookstore.

8-inch water mains are located below the Common Mall pavement (aligned north-south) and in North Campus Drive (aligned east-west). Domestic and fire water services to Surge Building, University Lecture Hall, the HUB Complex are provided from these water mains. Location of domestic and fire water lines servicing the Bookstore could not be determined from the as-built plans nor from the Physical Plant staff. Therefore, the magnitude of utility impacts due to the proposed development could not be determined.

The existing landscaped berm located at the north and north-west façade of the Bookstore is irrigated by an irrigation supply pipe located in the berm.

OPTIONS 1 AND 2:

Available ground cover for the water pipes located within the Service Road ranges from approximately 3-feet to 5-feet. Since the scope of work within this area is to provide raised crosswalk, relocation of water pipes is not anticipated.

Location of domestic and fire water lines servicing the Bookstore building could not be determined from the as-built plans nor from the Physical Plant team. Therefore, a magnitude of utility impact due to the proposed development could not be determined. If it is determined that new connections will be required to meet additional domestic and firewater demands for the proposed interior renovations, service can be either be tapped either off of the existing 8-inch water main located south of the bookstore building or the existing 8-inch water main located east of the bookstore building pending verification of capacity and pressure availability by the Physical Plant team. New domestic and fire water service will be provided with backflow prevention devices to prevent cross contamination.

An existing irrigation pipe feeds the landscaped berm, and it will be impacted due to lowering of the grade at the north and north-west façade of the Bookstore. It is our assumption that new irrigation lines required for new plantings in the Lower Plaza and the Commons Mall will be hooked up to the existing controller at the Hub Plaza. Capacity of the existing controller to meet new irrigation demands should, however, be verified as part of the due diligence for the design project by the Irrigation Consultant.

Refer to figure C3.0 for combined water distribution system diagram.

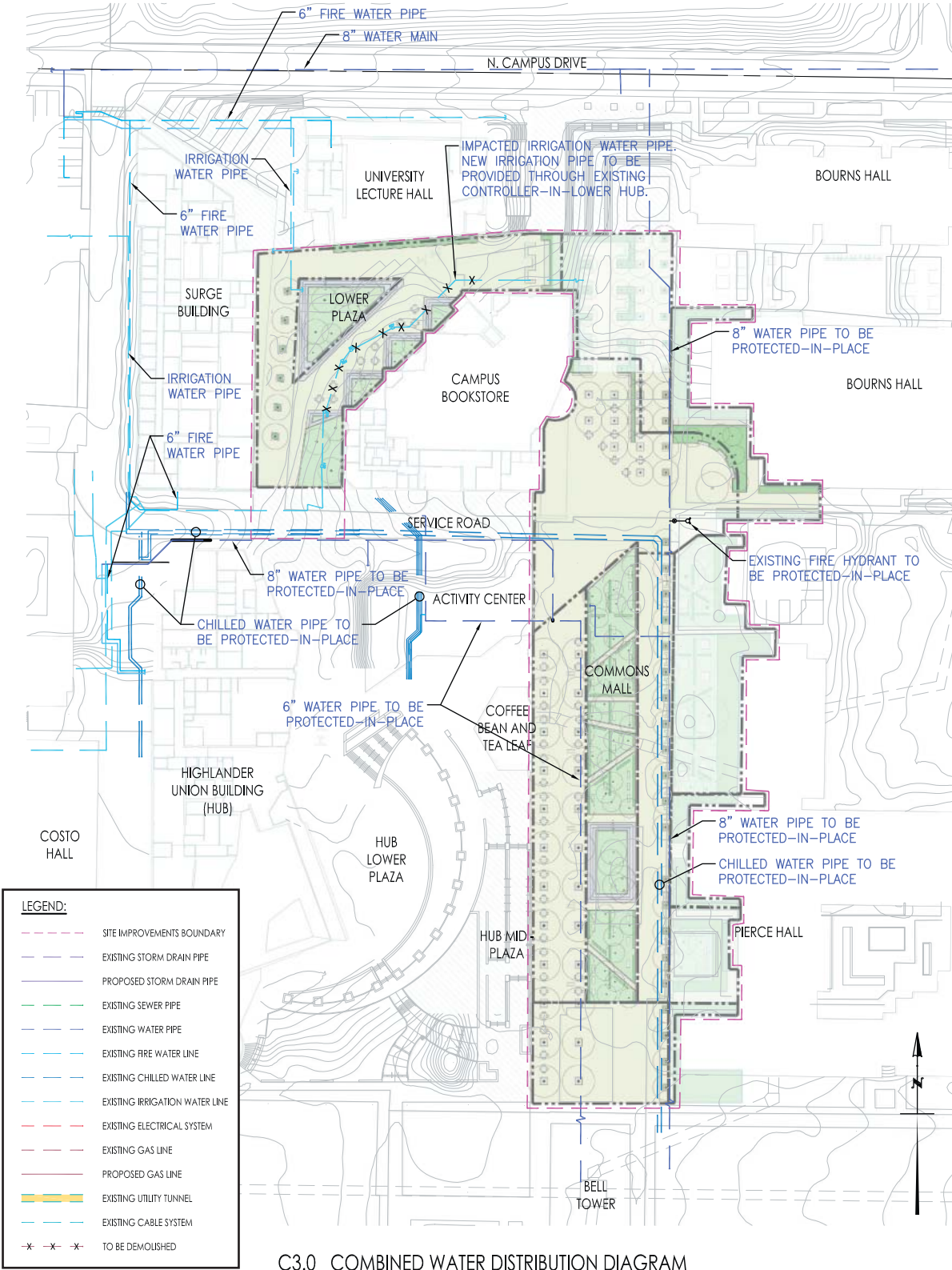

C4.0 POWER

EXISTING CONDITIONS:

Per as-built drawings, an electrical duct bank, approximately 5.5 feet deep x 3 feet wide, aligned west-east, is located 6-inch below grade within the Service Road. The duct bank makes a curved return and runs along the west face of the Bookstore eventually connecting to the building from below the landscaped berm on the west side. Also located in the landscaped berms are two electrical vaults. Please refer to Electrical Design Narrative for further information concerning the site electrical distribution system.

As-built drawings also indicate an electrical conduit aligned from the first bay window of the Bookstore building across the Lower Plaza to the Surge Building.

OPTION 1:

Part of the landscaped berm located on the west side of the Bookstore is proposed to be protected in place, thereby avoiding relocation of the duct bank and the vaults.

OPTION 2 (PREFERRED):

Adequate information regarding horizontal and vertical positioning of the electrical conduit aligned from the first bay window of the Bookstore building is not known at this time. Potholing investigation will be needed to determine the location and size of the conduit to determine impact on the conduit due to proposed change in grade elevation work and feasibility of relocation of the conduit.

Refer to figure C4.0 for power distribution system diagram.

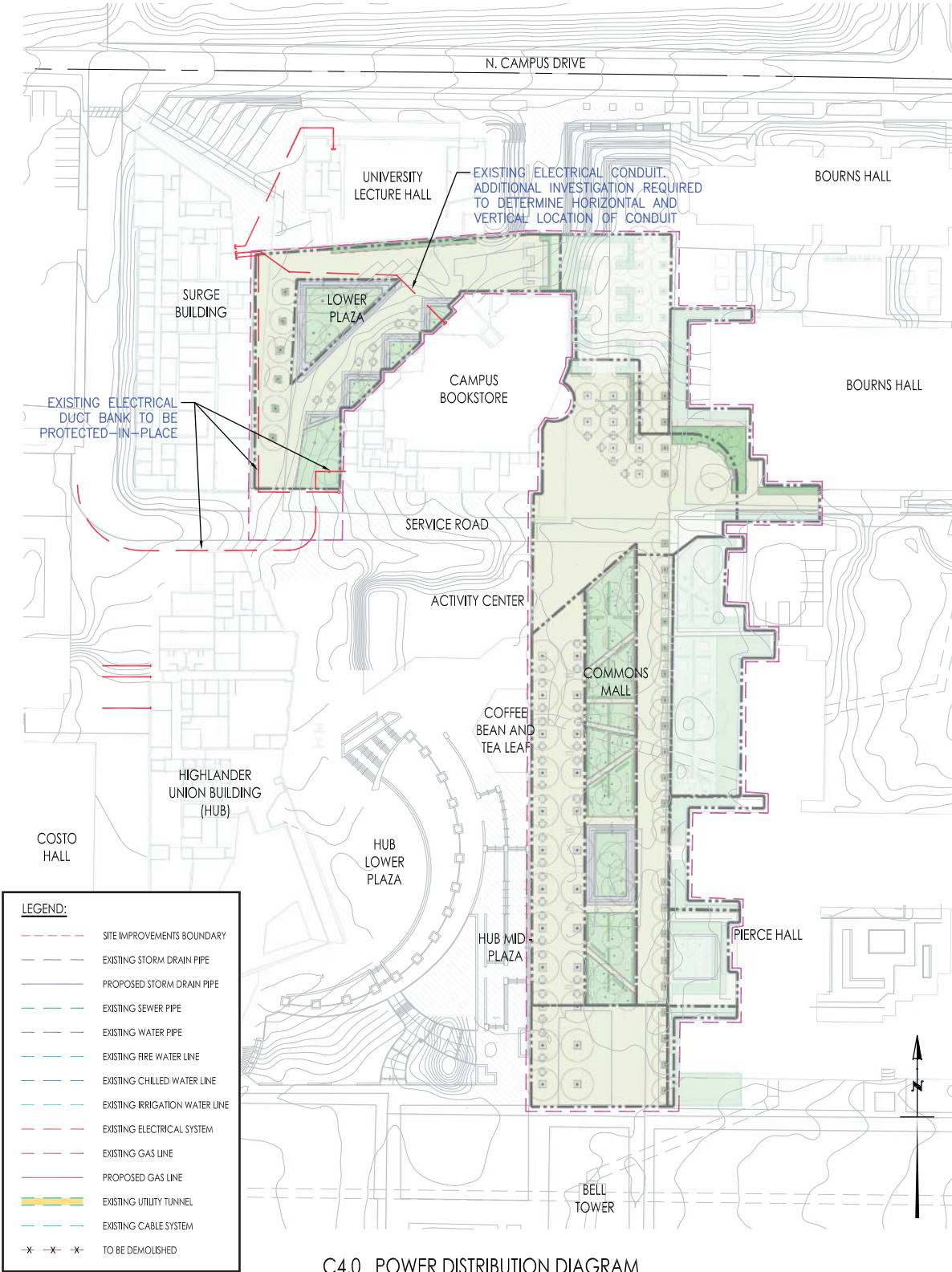

C5.0 GAS

EXISTING CONDITIONS:

A gas pressure regulator is located on top of the landscaped berm, in front of the second bay window, north-west of the Bookstore. Medium gas pressure pipes feed off from the gas regulator providing service to Surge Facility, Athletics and Dance Building, University Lecture Hall and the Activity Center. Within the Service Road limits of work, 2-inch and 1.5 inch gas pipes are located approximately 3-feet below grade (assumed per Industry Standards).

OPTION 1:

As the scope of work under Option 1 is to raise the grade to provide an elevated walkway between the Lower Plaza and the Hub Plaza, existing gas lines are anticipated to be protected-in-place.

OPTION 2 (PREFERRED):

Under Option 2, to accommodate a grade change north of the Bookstore, the existing gas pressure regulator with the feeder pipes will be required to be relocated. Gas pipes sizing is a function of the demand (loads) and pipe length. Per our research, gas lines may be relocated without the need for upsizing the pipe size provided current demand is sufficient and an increase in demands and routing lengths will not be required as a part of the proposed improvements. Please note, gas regulators require an independent vent to the outdoors and therefore should be located in open spaces to avoid hazardous conditions.

Detailed recommendations and relocation design will be part of Schematic Design

Refer to figure C5.0 for gas distribution system diagram.
C6.0 Other Utilities

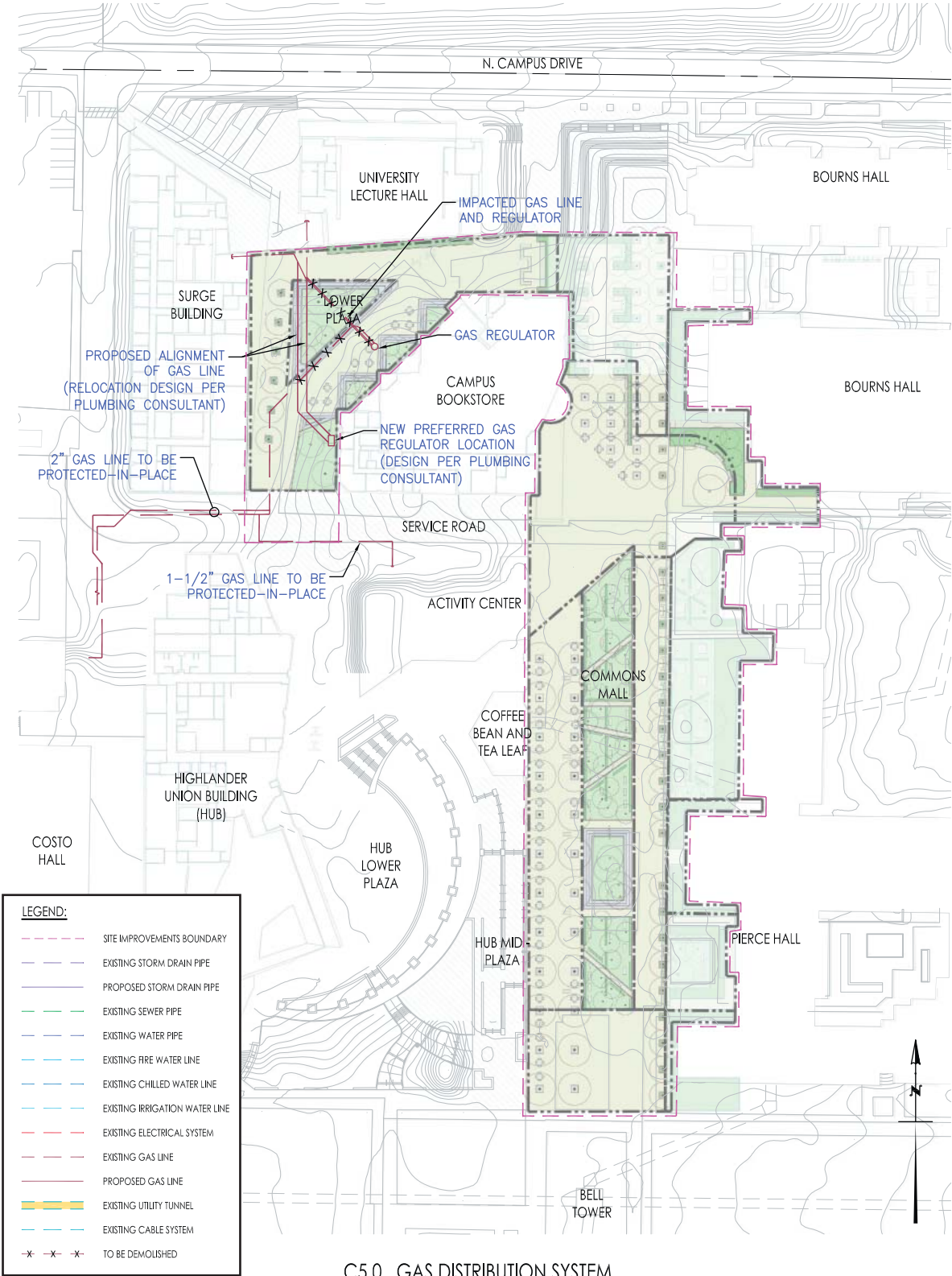

UTILITY TUNNEL

EXISTING CONDITIONS:

Per the existing information, a 6.5 feet diameter utility tunnel is located beneath the Commons Mall and runs east to west from the Hub Plaza to Pierce Hall located on the east side of the Commons Mall. Per utility potholing investigations, the top of the tunnel is approximately 4.5 feet below ground surface.

OPTIONS 1 AND 2:

The footprint of the utility tunnel is located within landscaping designated zones A, B, D and F. The utility tunnel is not anticipated to bear any impact due to lowering of grade at the north end of zones A and D. Root barriers maybe required for protection where new trees are located close to the utility tunnel.

TELECOMMUNICATIONS/CABLE SYSTEMS

A cable system is located within North Campus Drive street limits and is considered to be out of the proposed project improvements.

Refer to figure C6.0 for miscellaneous utilities information.

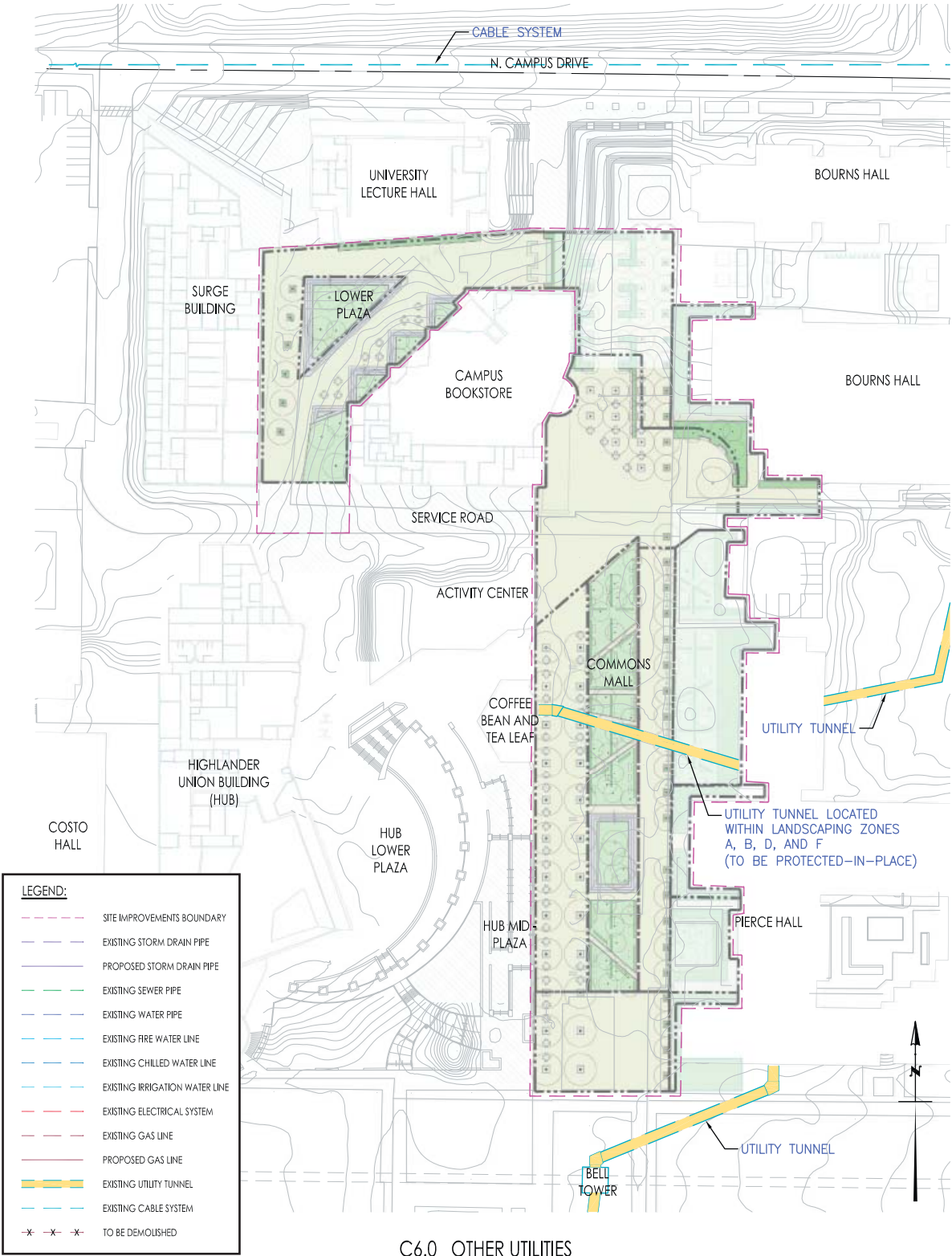

STRUCTURAL DESIGN NARRATIVE

1. PROJECT DESCRIPTION

The Commons Mall and Bookstore Renovation and Enhancement project at UCR is proposed to consist of various exterior and interior improvements to be made in and around the Campus Bookstore. The structural scope of work is limited to the proposed modifications and/or additions to the existing Bookstore. All existing structural information is based upon the provided drawings by Hope Architects and Engineers, dated 6/25/90. Further details regarding the existing conditions and proposed structural work are included below.

2. EXISTING CONDITIONS

2.1 EXISTING BOOKSTORE BUILDING GRAVITY SYSTEM

The gravity system at the roof level of the existing two-story Bookstore consists of an un-topped, 1-1/2" thick metal roof deck spanning between wide-flanged steel beams. These steel beams span between wide-flanged steel girders which, in turn, are supported by columns below.

The gravity system at the second level consists of a 3" thick metal floor deck which is topped with 2-1/2" of lightweight concrete (total 5-1/2" thickness). The deck spans between wide-flanged steel beams which, in-turn, span between wide-flanged steel girders. Both the beams and the girders have been constructed as composite beams, with headed shear studs connecting the deck to the beams. Steel columns below support all girders.

The columns at both levels are mostly wide-flanged steel sections; however there are a few locations where tube steel sections are utilized. The typical maximum spacing between columns is 30' and they run continuous from roof level to foundations, with no discontinuities or transfers noted.

2.2 EXISTING BOOKSTORE BUILDING LATERAL SYSTEM

The lateral system of the building mostly consists of fully-grouted, CMU shear walls in each direction. These shearwalls are typically located around the perimeter of the structure; however there are a few interior locations as well. The attached diagrams show locations of shearwalls as read from the existing structural drawings. The majority of the perimeter shearwalls have been constructed with various punched window openings within the length of the walls.

In between the ground floor and the second floor, on the southeast side of the structure, there is a CMU retaining wall. This wall retains the on-grade portion of the second level and also doubles as a shearwall.

Also in between the ground floor and the second floor, on the northwest side of the structure, there are a series of concrete shearwall piers. These concrete shearwalls become CMU at the floor level above and a portion of these CMU walls are discontinued on top of adjacent steel framing.

Typically the lateral shearwall system of the building is independent of the gravity system, with steel columns located directly adjacent to the shearwalls.

2.3 EXISTING BOOKSTORE BUILDING FOUNDATIONS

The foundation system for the existing building consists of shallow spread footings located underneath each of the steel columns and continuous footings underneath each of the shearwalls. The top of most of the foundations are located fairly close to the finish surface level, with an average of about 1' below finish surface.

2.4 EXISTING SITE SOIL CONDITION

As this project is in its' preliminary stages, project specific geotechnical information is not available. A geotechnical investigation report was conducted for the original Bookstore construction and has been reviewed in regards to the proposed expansion. This investigation was performed by John R. Byerly, Inc. (Report No. 3574, File No. S-7395) and is dated May 18, 1989.

Based upon the borings performed as part of the provided geotechnical report, the soil below the Bookstore was originally covered in relatively little fill material; varying in depth between 2' and 6'. This fill material was to be removed as part of the Bookstore construction and all new foundations were to bear on a 2' deep layer of recompacted fill. No groundwater was encountered when borings were, up to 29' deep, were conducted and liquefaction was not mentioned an issue.

While the provided geotechnical report may be used as a guide to determine design values for any new foundations, a project specific geotechnical investigation may be warranted depending on the ultimate extent of any foundation work required.

3. PROPOSED MODIFICATIONS

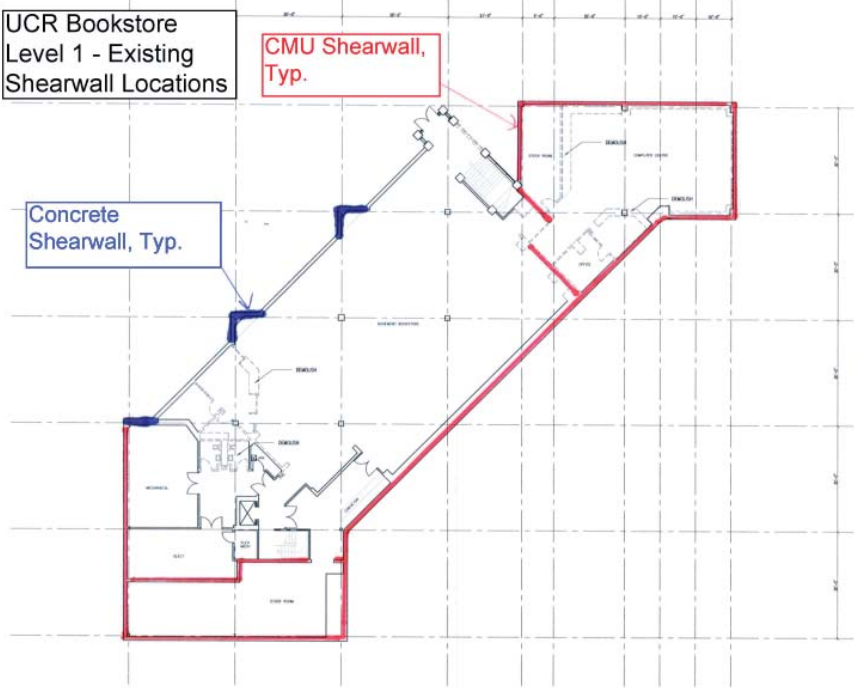

FIGURE 1 – EXISTING SHEARWALL LOCATIONS AT LEVEL 1

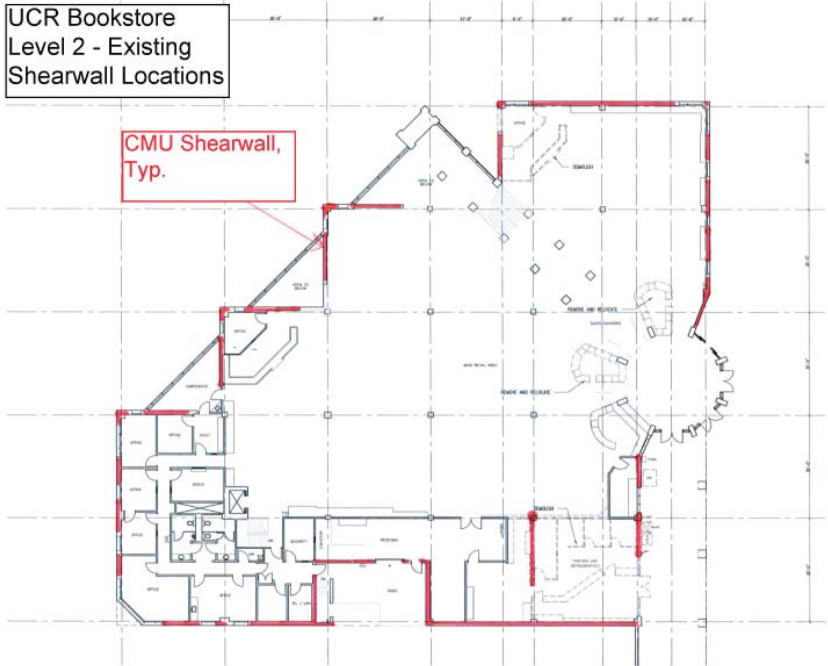

FIGURE 2 – EXISTING SHEARWALL LOCATIONS AT LEVEL 2

MECHANICAL DESIGN NARRATIVE

The following narrative provides a general overview of the renovation of the HVAC and Plumbing systems that will be provided for the UCR Commons Mall and Campus Bookstore Renovation and Enhancement DPP. The building is approximately 20 years old, a two-story structure with CMU exterior walls. The project has a goal of achieving a LEED Silver rating for the lower level tenant areas of the Bookstore, and an energy efficiency goal of 20% better than CEC T24 requirements.

1.1 CODES AND STANDARDS

Codes

- California Mechanical Code, latest version.
- California Building Code, latest version.
- California Fire Code, latest version.
- California Energy Code Title 24

Standards

- ANSI - American National Standards Institute.
- UL - Underwriters Laboratories
- AGA - American Gas Association.
- ASME- American Society of Mechanical Engineers
- ASHRAE - American Society of Heating, Refrigeration & Air Conditioning Engineers.
- ARI - American Refrigeration Institute
- ASTM - American Society for Testing Materials
- IACCUC - International Association of Conference Centers Universal Criteria.
- NFPA - National Fire Protection Association

1.2 DESIGN CRITERIA

• OUTDOOR CLIMATIC CONDITIONS.:

The HVAC systems design will be based on the following: Outdoor temperatures (based on the 0.5% summer and 0.2% winter Design ASHRAE Climatic Data for Riverside, California). This design data complies with the CEC Title 24 design requirements.

- o Summer: 102°F DB, 69°WB
- o Winter 29°F DB
- o Climate Zone 10
- o Latitude 34
- o Elevation 986 ft.

• INDOOR DESIGN TEMPERATURES.

- o Summer: 75°F +/- 4
- o Winter 70°F +/- 4

• VENTILATION RATES.

- o The mechanical ventilation system shall comply with ASHARE Standard 62 and California Energy Efficiency Standard Title 24. The ventilation rate shall not be less than 0.15cfm/sq or 15cfm per person, the higher rate shall apply to all spaces. Occupancy shall be determined based upon code except where specific numbers of occupants are provided by the University as indicated below.

1.3 EXISTING HVAC SYSTEMS AND DEFICIENCIES

The entire building is served by a single air handling unit, which is located in the lower level mechanical equipment room, which is also used as an outside air plenum. The system is of a single duct VAV type with terminal reheat. The return air duct is connected directly to the unit. The return and outside air sides of the mixing box are provided with modulating control dampers to allow for the economizer cycle. The unit is of a commercial grade and is at the end of useful service life. The unit frame is showing signs of corrosion near the bottom of the unit. The unit interior is polluted with dust, which is indication of poor air filtration. The use of the mechanical room as a plenum is an issue, due to the fact that during the cold period of the year the room temperature may drop below 50 degrees F, which may create conditions for mold growth. This should be corrected to eliminate potential health problems.

The chilled water is provided by the Campus Central Plant with the chilled water main branching off in the HUB located across the driveway and delivering it to the project site underground.

A tertiary chilled water, constant volume pump is provided to boost water pressure in the piping system feeding the cooling coil. The constant flow pump is energy wasteful and should be provided with variable frequency drive (VFD). Heating hot water is also provided from the HUB.

The HVAC controls are of a pneumatic type and are of original installation. The supply air temperature sensor is removed from the duct, which is an indication that the controls are in need of upgrade or replacement.

1.4 HVAC SYSTEMS MODIFICATIONS

A number of possible heating and cooling systems have been suggested as indicated below:

The existing air handling system including the air handling unit should be modified in order to accommodate the minor addition of the square footage. The air handling unit filtration shall be upgraded and ducts should be environmentally cleaned by a licensed contractor. Regardless, if this option is approved or not, the duct cleaning should be provided to

make this building environmentally safe.

- Radiant Floors for Heating and Cooling in combination with a Displacement Ventilation System.
 - o Radiant Floor: Pex piping is integrated into a 3" topping slab, insulation is placed between the topping slab and the structural slab. The flooring finish is installed on the topping slab. Heating hot water is circulated through the piping to transfer heat into the space or chilled water is circulated through the piping to absorb heat from the space.
 - o Displacement Ventilation: Tempered air is supplied to the space through low level diffusers located in thickened walls. The volume of air delivered is based on the required ventilation rate for the space rather than the heating or cooling load, therefore the air volume, ductwork and the AHU are 20% smaller than conventional systems. In addition the ventilation air is supplied at 63F which extends the use of free cooling and reduces the chiller size and energy usage. A semi-custom AHU will be specified. (Energy Labs or Equal) dedicated to the expansion will be provided separately from the existing in the building air distribution system. The unit location will be in the existing mechanical equipment room
- Electric Heat Pump Packaged Unit (Rooftop or on grade)
 - o Electric heat pump packaged heating and cooling unit may be considered on the building roof or on grade to provide heating, cooling and ventilation to the renovated space. The system will be a conventional all air system with zone control provided by VAV boxes with reheat coils. (Approximately 25 to 30 tons). The most efficient unit available in this size will be specified. (McQuay Packaged Unit or Equal)

PLUMBING

The following narrative provides a general overview of the existing plumbing systems serving the Bookstore. It has been determined that existing building has adequate capacities for gas, water and sewer infrastructure to support the proposed remodeling in terms of plumbing systems design. The project has a goal of achieving a LEED Silver rating for the lower level tenant areas of the Bookstore.

1.5 CODES AND STANDARDS

Codes

- California Plumbing Code, latest version.
- California Building Code, latest version.
- California Fire Code, latest version.
- California Energy Code Title 24
- NFPA 13 Automatic Sprinkler Systems
- NFPA 14 Standpipe Systems
- NFPA 72 National Fire Alarm Codes (California Amendments)

Standards

- ANSI - American National Standards Institute.
- UL - Underwriters Laboratories
- AGA - American Gas Association.
- ASME - American Society of Mechanical Engineers
- ASHRAE - American Society of Heating, Refrigeration & Air Conditioning Engineers.
- ARI - American Refrigeration Institute
- ASTM - American Society for Testing Materials
- IACCUC - International Association of Conference

Centers Universal Criteria.

- NFPA - National Fire Protection Association

1.6 PLUMBING SYSTEMS

The project contains male and female restrooms as well as ADA compliant restrooms. Low flow fixtures will be utilized for water conservation. A new domestic hot water system shall be provided for the facility.

- HVAC Condensate Drainage
HVAC condensate drainage piping shall be provided to each HVAC unit. Such piping shall drain to an indirect waste connection at the nearest floor sink.
- Plumbing Fixtures
To achieve water savings low water use fixtures will be specified. The LEED requirements for one point is to employ strategies that in aggregate use 20% less water than the water use baseline calculated for the building (not including irrigation) after meeting Energy Policy Act of 1992 fixture performance requirements.

1.7 ENERGY MANAGEMENT SYSTEM

There is no central EMS at the existing facility, the project will be provided with a stand alone EMS for HVAC equipment control, plumbing equipment monitoring. The system will be DDC, the campus preferred manufacturer is Siemens.

ELECTRICAL DESIGN NARRATIVE

1.1 GENERAL

Our office visited the UCR Bookstore and Commons Mall on January 13, 2011 to review the existing electrical systems. Following is an outline of our findings and preliminary recommendations for the proposed renovations within the existing Bookstore and the existing area.

1.2 BUILDING POWER SERVICE

Existing Conditions:

The Bookstore is connected to the campus medium voltage distribution system. The underground medium voltage service enters the building from the site on the west side and terminates in an indoor unit substation, which is located in the main electrical room. The unit substation line up includes a medium voltage switch, a 500KVA dry type transformer, a main breaker section, and a distribution section. The medium voltage distribution transformer has a dual 4160/12470 volt primary with a 120/208Volt 3 phase, 4 wire secondary. The distribution section is rated at 120/208Volt 3 phase, 4 wire, 1000 amps. The substation line-up appears to be good condition.

RECOMMENDATIONS:

Based on the current program the existing service equipment size will be adequate to serve the proposed and existing loads. Should the program change (for example the addition of food service), we would recommend that the service size be evaluated to ensure that it will be adequate. As part of the due diligence for the project, we recommend that

the equipment undergo testing as part of the construction project.

1.3 DISTRIBUTION SYSTEM

Existing Conditions:

There are a number of panel boards located throughout the building. The panel boards are connected to the main switchboard via a network of feeders. The building does not appear to have an emergency generator. (Not anticipated to be required.)

RECOMMENDATIONS:

The existing panel boards and feeders can remain in place as long as they are not in the way of the remodel work. For areas to be remodeled we recommend that new panel boards and feeders be added. For the lower level remodel we recommend one new 225Amp panel and feeder to serve the new receptacle and power loads, and a 100 amp panel and feeder to serve the new lighting loads.

For a major remodel of the Bookstore area we would recommend a new 225Amp panel and feeders to serve the receptacle loads, and a new 100Amp panel and feeders to serve the new lighting loads.

New feeders will be required to be installed from the main switchboard to the elevator machine room.

1.4 LIGHTING

EXISTING CONDITIONS:

The second floor retail area of the Bookstore is served primarily by fluorescent light fixtures. The majority of the light fixtures are lay-in ceiling type with surface mounted fluorescent light fixtures located around the perimeter of the sales area. There is also a number of pendant and wall mounted sconces located throughout the building. The conduits to a number of the wall mounted sconces are cast into the existing concrete and brick walls.

There does not appear to be a lighting control system in the building. The switching generally consists of wall mounted light switches.

RECOMMENDATIONS:

For areas scheduled for renovation it will be necessary to upgrade the lighting to comply with Title 24. This new lighting would need to use state of the art energy efficient lamps and ballast not only to comply with California Title 24 requirements, but to also exceed Title 24 targets which will be necessary to achieve LEED credits. The lighting design will also need to comply with the California Green Building Standards (CALGreen). As a number of the existing wall mounted sconces light fixtures are using existing cast in place conduit and boxes, every effort should be made to reuse the raceways for new wiring to new wall mounted light fixtures.

We recommend that for any areas of remodel in the Bookstore that new lighting systems be considered. The new lighting should be designed to the latest retail approach to retail lighting to help improve the overall sales area.

Following are recommended lighting budget costs for consideration. All costs listed below include estimates for light fixtures (including standard electronic ballasts), installation, labor, and miscellaneous hardware, and branch wiring back to other fixtures, panel boards, or lighting control relay panels. These estimated square foot costs do not include lighting branch panels or feeders, light switches, wall dimmers or other control equipment or wiring.

AREA/ROOM	COST/S.F.
Bookstore Retail Area	\$16.50 / s.f.
Public circulation Spaces (Lobbies, Corridors, etc.)	\$15.50 / s.f.
Office and Administration Areas (including Conference Rm.)	\$13.50 / s.f.
Staff & 'Back of House' Spaces	\$12.50 / s.f.

For areas of remodel it will be necessary to upgrade the emergency lighting to comply with current building codes. This will be best achieved using a central emergency lighting inverter. For a remodel of the Lower Level, a 2KVA inverter with 90 minutes of battery backup could be used. For a larger remodel including the upper level retail spaces, portions of the Bookstore including egress paths and exterior emergency lighting, a 5KVA inverter with 90 minutes of battery could be used. This KVA sizes are preliminary for budget purposes only.

To comply with California Title 24 new lighting controls will be required in areas of remodel. The new system will need to incorporate all the necessary Title 24 automatic sweep off functions. Also the opportunity to integrate daylight harvesting systems integrated with dimming systems should be considered for areas with daylight opportunities such as Career Center Library, and Reception area. Local wall and ceiling mounted occupancy sensors should be considered in storage rooms, janitor closets, and other transitory rooms to maximize energy efficiency.

1.5 FIRE ALARM SYSTEM

EXISTING CONDITIONS:

The building currently has a fire alarm system. The building main fire alarm panel is located in the corridor area adjacent to the main electrical room. There is a remote annunciator located at the loading dock. Fire alarm devices are located throughout the building, consisting of horn/strobes, and pull stations.

RECOMMENDATIONS:

For a major remodel of the building we would recommend that a new fire alarm panel and new fire alarm devices and wiring be installed to replace the existing system. Also, for a major remodel, new fire alarm devices will be required to be installed in all remodeled spaces to comply with current codes.

For a minor remodel it could be feasible to add a small number of new devices to the existing fire alarm panel. This would most likely require an expander panel with battery back up to power any new fire alarm devices that may get added.

1.6 TELECOM SYSTEMS

EXISTING CONDITIONS:

The Bookstore has a main Telecom Room located adjacent to the Loading Dock. Backbone cabling infrastructure enters the Telecom Room from a series of conduits routed via the lower level Storage Room, which appears to originate from a pull box that is connected to the existing site infrastructure.

RECOMMENDATIONS:

To minimize disruption to the backbone infrastructure from the site, we recommend that the existing Telecom Room, together with the conduit infrastructure within the Storage Room remain in place. This conduit infrastructure appears to have spare capacity should it be determined that additional copper and fiber backbone cabling is required for the building.

For the new building program it will be necessary to install new telephone/data wiring throughout the remodeled spaces, together with wiring to new wireless access points. In addition to the telephone/data wiring, new POS (Point of Sale) data wiring will be required to new designated locations within the Bookstore and the Card Office.

1.7 WIRING DEVICES

EXISTING CONDITIONS:

The existing receptacles and branch circuit wiring appear to be in good condition.

RECOMMENDATIONS:

New outlets together with new branch circuit wiring will be required to serve the remodeled spaces. These new devices will need to be connected to the new branch circuit panel boards.

EXISTING CONDITIONS:

The building has an existing security panel, which is located in the Telecom Room. The system appears to be in reasonable condition and is operational. Only one access control reader was observed which was located at the entry door from the Loading Dock.

There is an existing CCTV system in the building, which is wired to head end equipment located in a room adjacent to the Telecom Room.

RECOMMENDATIONS:

For a major remodel of the building we would recommend that a new security panel be installed with new wiring to new alarm devices located throughout the building. The system will need to be designed to allow zoning of the building so that the different areas of the building such as the Career Center can be armed while the Bookstore remains open.

For a minor remodel of the Bookstore and a remodel of the lower level the existing panel could be reused. New devices in the remodel spaces would need to be homerun to the existing security panel. If the existing security panel is reused it will need to be modified to allow zoning of the building so that the different areas of the building such as the Career Center can be armed while the Bookstore remains open.

We understand from discussions with campus personnel during our site visit that the University is currently looking at replacing the CCTV system with a new system.

New power branch circuits will need to be installed to service new Bookstore anti theft gates.

1.8 BACKGROUND MUSIC SYSTEM

Existing Condition:

The Bookstore has an existing background music system.

RECOMMENDATIONS:

We recommend the existing background music system remain in place with speaker relocations and wiring adjustments as required for any remodeled areas.

1.9 SITE ELECTRICAL

EXISTING CONDITIONS:

There are two underground electrical pull boxes located in the lawn area on the west side of the Bookstore. Based on the pull box covers it appears one box is used for 12KV distribution, and the second box is used for 480 Volt distributions. The 12KV pull box may be used for the electrical service routing to the Bookstore, as it appears to line up with the main Electrical Room within the building. As built information will be required to confirm the routing of the site electrical distribution systems.

RECOMMENDATIONS:

To minimize power system disruption, and avoid potentially high costs, we recommend that the two existing pull boxes remain in place.

1.10 SITE TELECOM

EXISTING CONDITIONS:

The underground telecommunications systems appear to enter the building from the south. The conduits rise up from underground to a wall mounted NEMA 3R pull can, which is surface mounted and is located on the wall to the left of the loading dock. The conduits and wiring appear to enter the building into the Stock Room and then continue to the main Telecom Room as noted above under Telecom Systems 1.6. In addition to the conduits going to the Telecom Room these are a number of other conduits travelling to other areas such as the electrical room from the site via the Stock Room including an existing backboard in the corner of the Main Electrical Room. The exposed conduit and wiring infrastructure from the site appear to be in good condition.

RECOMMENDATIONS:

We recommend that the existing underground telecom utility conduits remain in place including the exterior surface mounted pull can and the interior conduit infrastructure within the Stock Room, which is the path to the Building MPOE (Main Point of Entry). Further study and coordination will be required with the University to determine if new cabling will be required to the building.

1.11 MALL AREA LIGHTING, POWER, AND TELECOM SYSTEMS

EXISTING CONDITIONS:

During our site visit we reviewed the area of the Commons Mall being considered for enhancement and renovation. The existing Mall area has a number of pole mounted light fixtures, which appear to be from the existing construction of the Mall area. We did not observe any power outlets or emergency phones.

RECOMMENDATIONS:

For a major renovation we would recommend new energy efficient lighting. Newer technology LED lighting should be considered, however any light source selection needs to be coordinated with the University to ensure it meets the overall campus site lighting master plan, complies with the campus design standards, and enhances the design approach used at the HUB Complex.

Landscape lighting will also need to be considered for the Mall. Controls of new lighting will need to be integrated into campus control systems.

New power sources will need to be considered for event power in the Mall. New power sources will most likely need to be obtained from one or more of the existing buildings adjacent to the Mall.

Consideration should also be given to adding data and POS connections in the Commons Mall area for special events. Also wireless data should be considered for the Commons Mall area.

Consideration should also be given to the installation of emergency phones based on the campus requirements and standards.

INTRODUCTION

The Commons Mall and Bookstore Enhancement and Renovation project will make sustainable choices for updated materials, equipment, fixtures and finishes. Site improvements will increase water efficiency with sustainable plant selections and installation of a new irrigation controller, preserve natural habitat by saving mature/heritage trees and reduce energy use with new site lighting. Building improvements on the upper floor will include environmentally responsible material choices, improved lighting through re-fixturing with high efficiency lamps, and maintenance of existing building systems.

This project will aim for LEED for Commercial Interiors Silver certification for lower floor building improvements. Here, the larger scope of work makes it feasible to install new efficient lighting and replace the existing air handling unit to LEED standards. On the building perimeter, new larger window and door openings will increase views and daylighting. New toilet rooms will use water efficient fixtures. Selection of new finishes and ceiling materials will factor in LEED standards for recycled and local materials. Attached is a preliminary LEED chart that will track performance for the two lower floor tenant spaces and shared back of house spaces.

LEED 2009 for Commerical Interiors

The prerequisites are required and must be achieved, indicated by a "Y" in the "Y" column.

Yes			Maybe			No			Responsibility	OPTION		
11	6	2										
										Sustainable Sites		26 Points
Y									Prereq 1	Construction Activity Pollution Prevention	Required	
									Credit 1	Site Selection	1 to 5	
		1							Credit 1 Path 3	Site Selection- Stormwater Design- Quality Control	1	
1									Credit 1 Path 4	Site Selection- Heat Island Effect - Non roof	1	
1									Credit 1 Path 7	Site Selection- Water Efficient Landscaping- Reduce by 50%	1	
6									Credit 2	Development Density & Community Connectivity	6	
3	3								Credit 3.1	Alternative Transportation, Public Transportation Access	6	
									Credit 3.2	Alternative Transportation, Bicycle Storage & Changing Rooms	2	
	2								Credit 3.3	Alternative Transportation, Parking Availablability	2	
										Water Efficiency		10 Points
6	0	0							Prereq 1	Water Use Reduction - 20% Reduction	Required	
6									Credit 1	Water Use Reduction	6 to 11	
										Energy & Atmosphere		35 Points
14	10	5							Prereq 1	Fundamental Commissioning of Building Energy Systems	Required	
Y									Prereq 2	Minimum Energy Performance	Required	
Y									Prereq 3	Fundamental Refrigerant Management	Required	
5									Credit 1.1	Optimize Energy Performance- Lighting Power	1 to 5	
3									Credit 1.2	Optimize Energy Performance- Lighting Controls	1 to 3	
5									Credit 1.3	Optimize Energy Performance- HVAC	5 to 10	
1									Credit 1.4	Optimize Energy Performance- Equipment and Appliances	1 to 4	
									Credit 2	Enhanced Commissioning	5	
	5								Credit 3	Measurement & Verification	2 to 5	
	5								Credit 4	Green Power	5	
										Materials & Resources		13 Points
3	6	5							Prereq 1	Storage & Collection of Recyclables	Required	
1									Credit 1.1	Tenant Space- Long Term Commitment	1	
		2							Credit 1.2	Building Reuse	1 to 2	
2									Credit 2	Construction Waste Management	1 to 2	
									Credit 3.1	Materials Reuse	1 to 2	
									Credit 3.2	Materials Reuse- Furniture and Furnishings	1	
1	1								Credit 4	Recycled Content	1 to 2	
	2								Credit 5	Regional Materials	2 to 2	
									Credit 6	Rapidly Renewable Materials	1	
	1								Credit 7	Certified Wood	1	

8. SUPPORTING DOCUMENTS
LEED CHECKLIST

10 2 3

Indoor Environmental Quality

15 Points

Y				Prereq 1	Minimum IAQ Performance	Required
Y				Prereq 2	Environmental Tobacco Smoke (ETS) Control	Required
			1	Credit 1	Outdoor Air Delivery Monitoring	1
1				Credit 2	Increased Ventilation	1
1				Credit 3.1	Construction IAQ Management Plan , During Construction	1
1				Credit 3.2	Construction IAQ Management Plan , Before Occupancy	1
1				Credit 4.1	Low-Emitting Materials , Adhesives and Sealants	1
1				Credit 4.2	Low-Emitting Materials , Paints and Coatings	1
1				Credit 4.3	Low-Emitting Materials , Flooring Systems	1
1				Credit 4.4	Low-Emitting Materials , Composite Wood and Agrifiber Products	1
1				Credit 5	Indoor Chemical & Pollutant Source Control	1
1				Credit 6.1	Controllability of Systems , Lighting	1
	1			Credit 6.2	Controllability of Systems , Thermal Comfort	1
1				Credit 7.1	Thermal Comfort , Design	1
			1	Credit 7.2	Thermal Comfort , Verification	1
	1			Credit 8.1	Daylight & Views , Daylight	1
			1	Credit 8.2	Daylight & Views , Views for seated spaces	1

2 2 0

Innovation & Design Process

6 Points

1				Credit 1.1	Innovation in Design : 95% Construction Waste Management	1
	1			Credit 1.2	Innovation in Design : Green Education	1
		1		Credit 1.3	Innovation in Design : Green Cleaning	1
1				Credit 2	LEED® Accredited Professional	1

4 3 2

Regional Priority Credits

4 Points

			1	Credit 1.1	EAc1.1	1
1				Credit 1.2	EAc1.3- Option 1 Equipment Efficiency	1
	1			Credit 1.3	EAc1.3- Option 1 Zoning and Controls	1
1				Credit 1.4	EAc1.3- Option 2 Path 1 15%	1
			1	Credit 1.5	EAc1.3- Option 2 Path 2 30%	1
1				Credit 1.6	MRc2- 75%	1
	1			Credit 1.7	MRc7	1
1				Credit 1.8	SSc3.1	1
	1			Credit 1.9	WEc1- 40%	1

Yes	Maybe	No
50	29	17

Total Possible Points 110

Certified: 40-49 points, Silver: 50-59 points, Gold: 60-79 points, Platinum: 80-110 points

9. CONCEPTUAL COST PLAN





COMMONS MALL LANDSCAPE ZONES

CONCEPTUAL COST PLAN

For purposes of a preliminary cost estimate, the Design Consultant Team provided a series of drawings and program summaries. The “kit of parts” for pricing included:

- Two options for the Bookstore Building improvements;
- 12 landscape zones with a matrix of amenities including paving, planting, walls and site amenities.
- Technical narratives with options for utility upgrades.

This information allowed the Project Management Team to select a preferred project scope within a total budget limit of \$8 million. The resulting Conceptual Cost Estimate includes the Project Scope which is listed in the Executive Summary and described in more detail in the rest of this report.

Page 5 shows the Overall Summary and Total Project Cost; below the line are Project Scope items that will be funded from other sources but included within this project scope. Potential Add Alternates for a trellis canopy at the Commons Mall and additional site signage are also listed; more or other alternates may be developed during design phases.

The prepared Cost Plan lists the cost basis and inclusions and exclusions in the estimate. Construction phasing is not included, but as the design moves forward, effort will be made to schedule work around academic calendars and keep retail operations open to the maximum extent possible.

See attached cost plan.



**CONCEPTUAL
COST PLAN**

for

**Common Mall and Bookstore Renovation and Enhancement
University of California, Riverside
Riverside, California**

July 5, 2011

CONCEPTUAL COST PLAN

for

**Common Mall and Bookstore Renovation and Enhancement
University of California, Riverside
Riverside, California**

Field Paoli
150 California, 7th Floor
San Francisco, California 94111

Tel: (415) 788-6606
Fax: (415) 788-6660

July 5, 2011

Davis Langdon 
An AECOM Company

301 Arizona Avenue
Suite 301
Santa Monica
California 90401
Tel: 310.393.9411
Fax: 310.393.7493
www.davislangdon.com
www.aecom.com

CONTENTS

	Page Nos.
Basis of Cost Plan	1
Inclusions	2
Exclusions	4
Overall Summary	5
Option 1 Summary	6
Overall Sitework Summary	7
Lower Level - Career Center/Card Office/Elevator Lobby (Option 1) Component Summary	9
Upper Level - Bookstore (Option 1) Component Summary	19
Sitework Summary	26
Additional Funding Provided by Others	33

BASIS OF COST PLAN

<u>Cost Plan Prepared From</u>	Dated	Received
Drawings issued for		
Civil Existing Utilities Exhibit, Existing Utilities Exhibit Marked-Up, Option 1 Exhibit, Option 2 Exhibit	03/04/11	03/10/11
Landscaping Landscape Matrix	03/04/11	03/10/11
Architectural Lower Level Demolition, Upper Level Demolition, Lower Level Phase 1, Upper Level Phase 1, Lower Level Phase 2, Upper Level Phase 2, Elevations, Entry 2, Entry 3	03/04/11	03/10/11
Structural Existing shear wall Plan Lower Level, Existing shear wall Plan Upper Level	03/04/11	03/10/11

Outline Specification / narratives

Discussions with the Project Architect and Engineers

Conditions of Construction

The pricing is based on the following general conditions of construction

A start date of June 2013

A construction period of 12 months

The general contract will be competitively bid with qualified general and main subcontractors

There will not be small business set aside requirements

The contractor will be required to pay prevailing wages

There are no phasing requirements

The general contractor will have full access to the site during normal business hours

INCLUSIONS

PROJECT DESCRIPTIONS

The project consists of improvements to the Commons Mall and Campus Bookstore interior at the University of California, Riverside campus.

The Cost Plan includes the following assumptions for building systems:

Foundations include spread footing to elevator tower, elevator pit and overexcavation below new slab footprint.

The vertical structure includes additional tube steel columns and jamb reinforcement to existing CMU wall where new openings occur.

Floor and roof structure include reinforced slab on grade, steel beam, metal deck with concrete infill, metal roof deck and miscellaneous framing and blocking.

Exterior cladding includes new aluminum framed curtain wall system, entry doors, enlarged aluminum shop front and perforated metal screen and signage. Signage and graphics "Latitude 55" to Activity Center is also included.

Roofing system includes rigid board insulation, membrane roofing, new skylights and miscellaneous caulking and sealants.

Interior partition includes metal stud framing, gypsum board lining and paint finish, interior door with sidelight.

Finishes include ceramic tile to restrooms, carpet to Career Center's offices and conference room, Card Office and retail sales area; vinyl composition tile to staff lounge and sales area walkways; stone tile to lobbies and stair passage way.

Allowances are provided for general building specialties and fixed casework.

Plumbing includes sanitary fixtures, waste, vent and domestic service pipework, floor drains and hose bibs and water heating equipment.

HVAC includes replacing chilled water pump, (1) new air handling unit, (11) VAV boxes, air distribution and return systems, controls, allowance for cleaning of ductwork, removal of existing and temporary air provisions.

Electrical includes machine, equipment and user convenience power, lighting, telephone/data, conduit & cable re audio/visual & MATV systems, fire alarm, card scan and security.

Fire protection includes automatic wet sprinklers - (reconfigure existing systems).

Site utilities include fire and domestic water, sewer, mains power & telecommunications/signals connections to (E) infrastructure (mainly protect-in-place, with relocation and upgrades to gas and storm drainage systems).

INCLUSIONS

Site preparation include demolition and removal of interior and exterior minor building structures.

Site development includes site clearing and grading, paving, furnishings, landscaping, irrigation, site drainage and site lighting.

BIDDING PROCESS - MARKET CONDITIONS

This document is based on the measurement and pricing of quantities wherever information is provided and/or reasonable assumptions for other work not covered in the drawings or specifications, as stated within this document. Unit rates have been obtained from historical records and/or discussion with contractors. The unit rates reflect current bid costs in the area. All unit rates relevant to subcontractor work include the subcontractors overhead and profit unless otherwise stated. The mark-ups cover the costs of field overhead, home office overhead and profit and range from 15% to 25% of the cost for a particular item of work.

Pricing reflects probable construction costs obtainable in the project locality on the date of this statement of probable costs. This estimate is a determination of fair market value for the construction of this project. It is not a prediction of low bid. Pricing assumes competitive bidding for every portion of the construction work for all subcontractors and general contractors, with a minimum of 4 bidders for all items of subcontracted work and 6-7 general contractor bids. Experience indicates that a fewer number of bidders may result in higher bids, conversely an increased number of bidders may result in more competitive bids.

Since Davis Langdon has no control over the cost of labor, material, equipment, or over the contractor's method of determining prices, or over the competitive bidding or market conditions at the time of bid, the statement of probable construction cost is based on industry practice, professional experience and qualifications, and represents Davis Langdon's best judgment as professional construction consultant familiar with the construction industry. However, Davis Langdon cannot and does not guarantee that the proposals, bids, or the construction cost will not vary from opinions of probable cost prepared by them.

EXCLUSIONS

Owner supplied and installed furniture, fixtures and equipment
Loose furniture and equipment except as specifically identified
Hazardous material handling, disposal and abatement
Compression of schedule, premium or shift work, and restrictions on the contractor's working hours
Testing and inspection fees
Architectural, design and construction management fees
Scope change and post contract contingencies
Assessments, taxes, finance, legal and development charges
Environmental impact mitigation
Builder's risk, project wrap-up and other owner provided insurance program
Land and easement acquisition
Cost escalation beyond a start date of June 2013
CCTV surveillance cameras
Roof drainage upgrades
Domestic and fire water booster pumps
Telephone/data 'active' equipment - including hubs, routers, LAN, servers, switches and the like
Utility connection charges and fees
Clocks
Public address system and music system
Audio-visual equipment
Upgrades to main power distribution equipment and feeders, 120 V
Air distribution upgrades at Bookstore (upper level)
Demolition of major structures
Window shades
Interior graphics other than interior code signage
New roofing membrane to existing roof
Reader board at Latitude 55

OVERALL SUMMARY

	Option 1
	\$x1,000
Building	
Lower Level - Career Center/Card Office/Elevator Lobby	2,178
Upper Level - Bookstore	1,225
Subtotal Building Construction	3,403
Sitework	2,683
Signage at Student Center - Entry 3	146
Signage - Career Center, Bookstore and Tech	116
Sub-total Building Construction with sitework and signage	6,349
Soft cost	20.00% 1,270
TOTAL Building Construction with sitework and signage with soft cost	7,618
Bookstore - FF & E	385
TOTAL Project Cost	8,003

Estimates of Additional Funding to be provided by Others, outside this project scope

1. Career Center Funding	
A. Career Center FF&E	156
B. Gas relocation and lowering windows at the Career Center	185
2. Parking Lot 19 Funding	
A. Service gates	74
B. Ramp	226
3. Alternates	
A. Trellis canopy	280
B. Additional HUB signage and pylon	199

Please refer to the Inclusions and Exclusions sections of this report

OPTION 1 SUMMARY

	Gross Floor Area	\$ / SF	\$x1,000
Lower Level - Career Center/Card Office/Elevator Lobby	8,251 SF	264.02	2,178
Upper Level - Bookstore	14,575 SF	84.03	1,225
TOTAL Building & Sitework Construction	June 2013		3,403

Please refer to the Inclusions and Exclusions sections of this report

OVERALL SITEWORK SUMMARY

	Gross Floor Area	\$ / SF	\$x1,000
Zone A	12,800 SF	35.23	451
Zone B	12,000 SF	30.07	361
Zone C	8,800 SF	21.51	189
Zone D	9,600 SF	30.26	291
Zone E	18,500 SF	28.47	527
Zone J	20,000 SF	39.61	792
Zone L	2,930 SF	24.90	73
TOTAL Sitework Construction	June 2013		2,683

Please refer to the Inclusions and Exclusions sections of this report

LOWER LEVEL - CAREER CENTER/CARD OFFICE/ELEVATOR LOBBY (OPTION 1) AREAS & CONTROL QUANTITIES

Areas

	SF	SF	SF
Enclosed Areas			
Career Center (includes staff lounge and toilet rooms)	6,949		
Card Office	942		
Elevator Lobby	360		
 SUBTOTAL, Enclosed Area	<hr/>	8,251	
 TOTAL GROSS FLOOR AREA		<hr/>	8,251

LOWER LEVEL - CAREER CENTER/CARD OFFICE/ELEVATOR LOBBY (OPTION 1) COMPONENT SUMMARY

	Gross Area:	8,251 SF		
			\$/SF	\$x1,000
1. Foundations			6.96	57
2. Vertical Structure			2.86	24
3. Floor & Roof Structures			2.40	20
4. Exterior Cladding			17.86	147
5. Roofing, Waterproofing & Skylights			0.61	5
<i>Shell (1-5)</i>			30.69	253
6. Interior Partitions, Doors & Glazing			17.89	148
7. Floor, Wall & Ceiling Finishes			25.52	211
<i>Interiors (6-7)</i>			43.41	358
8. Function Equipment & Specialties			5.50	45
9. Stairs & Vertical Transportation			5.45	45
<i>Equipment & Vertical Transportation (8-9)</i>			10.96	90
10. Plumbing Systems			8.87	73
11. Heating, Ventilating & Air Conditioning			53.32	440
12. Electric Lighting, Power & Communications			33.75	278
13. Fire Protection Systems			2.50	21
<i>Mechanical & Electrical (10-13)</i>			98.44	812
Total Building Construction (1-13)			183.49	1,514
14. Site Preparation & Demolition			11.68	96
15. Site Paving, Structures & Landscaping			0.00	0
16. Utilities on Site			1.94	16
Total Site Construction (14-16)			13.62	112
TOTAL BUILDING & SITE (1-16)			197.12	1,626
General Conditions	10.50%		20.72	171
Contractor's Overhead & Profit or Fee	4.00%		8.73	72
PLANNED CONSTRUCTION COST			July 2011	226.57
Contingency for Development of Design	13.00%		29.45	243
Escalation to Start Date (June 2013)	3.13%		8.00	66
RECOMMENDED BUDGET			June 2013	264.02
				2,178

<i>Item Description</i>	<i>Quantity</i>	<i>Unit</i>	<i>Rate</i>	<i>Total</i>
1. Foundations				
Overexcavation				
Overexcavate, backfill and recompact under building footprint, 5' deep	68	CY	20.00	1,360
Reinforced including excavations				
Reinforced concrete foundation	360	SF	30.00	10,800
Strengthening existing foundation	432	SF	40.00	17,280
Modify existing foundations for lowering window	1	LS	18,000.00	18,000
Pits				
Elevator pits	1	EA	10,000.00	10,000
				57,440
2. Vertical Structure				
Columns and pilasters				
Tube or pipe steel columns	70	LF	150.00	10,500
Miscellaneous				
Jamb reinforcing at existing CMU wall	622	LB	5.00	3,110
Allowance for strengthening existing shear wall	1	LS	10,000.00	10,000
				23,610
3. Floor and Roof Structure				
Floor at lowest level				
Reinforced concrete slab	360	SF	10.00	3,600
Dowel connection to existing concrete slab, allow 12" o.c.	92	EA	100.00	9,200
Miscellaneous				
Framing and blocking	1	LS	7,000.00	7,000
				19,800

<i>Item Description</i>	<i>Quantity</i>	<i>Unit</i>	<i>Rate</i>	<i>Total</i>
4. Exterior Cladding				
Interior finish of exterior wall				
Gypsum board wall lining including paint finish	3,605	SF	3.90	14,060
Patch, repair and paint as necessary existing gypsum board lining	3,605	SF	3.00	10,815
Windows, glazing and louvers				
Aluminum framed curtain wall system	602	SF	100.00	60,200
Aluminum framed storefront window	332	SF	85.00	28,220
Connect existing wall to new curtain wall system	28	LF	65.00	1,820
Aluminum framed storefront window - NW	226	SF	85.00	19,245
Patch, repair and paint as necessary existing gypsum board lining surrounding	500	SF	2.00	1,000
Exterior doors, frames and hardware				
Entry glazed door, double leaf	2	EA	6,000.00	12,000
				147,360
5. Roofing, Waterproofing & Skylights				
Waterproofing				
Waterproofing to elevator pit	1	EA	5,000.00	5,000
				5,000
6. Interior Partitions, Doors & Glazing				
Partition framing and cores				
Wall framing including metal stud, batt insulation and gypsum board lining to both sides and paint finish	7,154	SF	13.40	95,864
Shaft wall framing including metal stud, batt insulation and gypsum board lining to both sides and paint finish - elevator shaft	476	SF	14.90	7,092
Window walls and borrowed lights				
Glazed sidelights and transoms at doors to offices	77	SF	55.00	4,235

<i>Item Description</i>	<i>Quantity</i>	<i>Unit</i>	<i>Rate</i>	<i>Total</i>
Interior doors, frames and hardware				
Solid core wood doors, frames and hardware				
Single leaf	20	EA	1,700.00	34,000
Double leaf	2	EA	3,200.00	6,400
				147,591

7. Floor, Wall & Ceiling Finishes

Floors including base				
Screed leveling to existing slab to receive new floor finish	7,891	SF	3.00	23,673
Stone tile to elevator lobby	486	SF	16.00	7,776
Ceramic tile to restrooms	452	SF	14.00	6,328
Carpet to Career Center, conference room, Meeting room and offices	7,160	SF	5.00	35,800
VCT to staff lounge and machine room	351	SF	4.25	1,492
Walls				
Paint or sealer to existing CMU wall	350	SF	2.50	875
Ceramic tile to restrooms	1,060	SF	15.00	15,900
Allow for premium wall finish to Career Center	1,070	SF	13.00	13,910
Ceilings				
Gypsum board ceiling to restrooms	452	SF	10.00	4,520
ACT ceiling generally	7,997	SF	4.00	31,988
Allow for premium ceiling finish to Career Center	6,830	SF	10.00	68,300
				210,562

8. Function Equipment & Specialties

Prefabricated compartments				
Toilet partitions	5	EA	1,000.00	5,000
Urinal screens	1	EA	800.00	800
Toilet and bathroom accessories	9	EA	1,000.00	9,000
Shelving and millwork				
Allow for storage shelving	1	LS	2,000.00	2,000
Cabinets and countertops				
Relocating existing transaction counter at Card Office	20	LF	200.00	4,000
Allowance for miscellaneous FF&E to card office	935	SF	10.00	9,350

<i>Item Description</i>	<i>Quantity</i>	<i>Unit</i>	<i>Rate</i>	<i>Total</i>
General building specialties Fire extinguisher, cabinets, code, directional and room identification, signage	8,251	SF	1.85	15,264
				45,414

9. Stairs & Vertical Transportation

Elevator Hydraulic passenger elevator, 1 stop	1	EA	45,000.00	45,000
				45,000

10. Plumbing Systems

Sanitary fixtures and local connection pipework - motion activated flushing valves	13	Fx)		
Water closets	5	EA	1,550.00	7,750
Urinal	1	EA	1,575.00	1,575
Lavatories	4	EA	1,425.00	5,700
Sinks				
Counter-top, refuse disposal unit	1	EA	1,175.00	1,175
Service type	1	EA	1,750.00	1,750
Drinking fountains, dual-level	1	EA	3,750.00	3,750
Sanitary waste, vent and service pipework				
Floor drains and sinks, < = 6", complete with connection pipework, trap primers	2	EA	2,500.00	5,000
Hose bibs, 3/4"	1	LS	2,000.00	2,000
Rough-in sanitary fixtures, including waste, vent and domestic service pipework	13	EA	3,000.00	39,000
Condensate drainage, < 1"	1	LS	2,500.00	2,500
Water treatment, storage and circulation				
Domestic hot water heater, including flue, storage and circulatory equipment	1	LS	3,000.00	3,000
Surface water drainage				
Roof & overflow drains, < = 6",				existing
				73,200

<i>Item Description</i>	<i>Quantity</i>	<i>Unit</i>	<i>Rate</i>	<i>Total</i>
11. Heating, Ventilation & Air Conditioning				
Thermal expansion compensation and circulation Pumps				
Replace tertiary chilled water pump with variable speed drive & vibration isolation	1	EA	5,000.00	5,000
Piping, fittings, valves and insulation				
Chilled water pipework, fittings, < = 3" - equipment connections to new air handling unit, valves & specialties	1	LS	3,750.00	3,750
HHW pipework, fittings, < 3"	480	LF	30.00	14,400
Valves and specialties	1	LS	4,000.00	4,000
Insulation	480	LF	8.50	4,080
Air handing equipment				
Semi-custom air handling unit (Energy Labs or equal) double wall, supply & return fans, VFDs, manual by-pass, CC, mixing box and MERV 13 (85% efficiency) filter bank	35,000	CFM	5.50	192,500
VAV boxes with reheat coils	8	EA	875.00	7,000
Air distribution and return				
Galvanized sheet metal ductwork	9,000	LB	9.50	85,500
Flexible ductwork	375	LF	7.50	2,813
Dampers				
Volume	75	EA	45.00	3,375
Fire/smoke	1	LS	5,000.00	5,000
Insulation	6,500	SF	4.00	26,000
Diffusers, registers and grilles	8,251	SF	2.00	16,502
Controls and instrumentation - Allerton				
Direct digital energy management system - including CO2 monitoring	8,251	SF	4.50	37,130
Test and balance air systems				
Including testing of existing systems	124	HR	105.00	13,020
Unit ventilation/exhaust fans				
General exhaust				existing
Trade demolition	8,251	SF	1.50	12,377
Temporary air handling unit	1	LS	7,500.00	7,500
				439,946

<i>Item Description</i>	<i>Quantity</i>	<i>Unit</i>	<i>Rate</i>	<i>Total</i>
12. Electrical Lighting, Power & Communication				
Emergency power				
Battery inverter re emergency egress lighting	1	LS	4,750.00	4,750
Machine and equipment power				
Connections and switches, including conduit and cable				
Mechanical connections < 15 hp	3	EA	2,850.00	8,550
Miscellaneous connections, < 225 AM - including specialty, F/S dampers, BMS power, fire, IT and security systems	1	LS	15,500.00	15,500
User convenience power				
Panelboard breakers, 120 V circuits	84	EA	87.50	7,350
Feeder conduit and cable	200	LF	35.00	7,000
Receptacles, including conduit and cable	6,949	SF	4.50	31,271
Lighting				
Fixtures/switches, including conduit and cable	6,949	SF	14.00	97,286
Lighting and power specialties				
Lighting control - daylight dimming	6,949	SF	2.50	17,373
Telephone and communications				
Telephone/data - horizontal cabling, POS outlets & WAPs	6,949	SF	6.00	41,694
Audiovisual rough-in	1	LS	6,000.00	6,000
Alarm and security				
Fire alarm systems				
Stations/devices, including conduit and cable	6,949	SF	4.00	27,796
Security - access control/motion sensors only	6,949	SF	2.00	13,898
				278,467
13. Fire Protection Systems				
Fire protection				
Automatic wet fire sprinklers - reconfigure existing lay-outs	8,251	GSF	2.50	20,628
				20,628

<i>Item Description</i>	<i>Quantity</i>	<i>Unit</i>	<i>Rate</i>	<i>Total</i>
-------------------------	-----------------	-------------	-------------	--------------

14. Site Preparation & Building Demolition

Selective demolition and removal

Carefully demolish and remove portion of existing foundation, 7' x 7 x 16" deep including breaking concrete slab	1	LS	10,000.00	10,000
Take down and remove existing interior partition	222	LF	20.00	4,440
Take down and remove gypsum board wall lining including finish to interior face of exterior wall, assume 50% of wall area	3,605	SF	1.00	3,605
Take down and remove existing door	6	EA	150.00	900
Take up and remove existing floor finish	7,891	SF	1.85	14,598
Take down and remove existing ceiling finish	7,891	SF	2.00	15,782
Take down and remove fixed cabinetry	75	LF	28.00	2,100
Take down and remove sanitary fixtures	5	EA	225.00	1,125
Create opening for new exterior entry door, double leaf width	2	EA	750.00	1,500
Take down and remove existing storefront at Stock Room and Card Office	336	SF	30.00	10,080

Site demolition, removal and site prep for lowering windows

Create window opening in concrete wall to accommodate larger storefront northwest window	226	SF	35.00	7,924
Clear existing site structures, existing paving and landscape berm	2,000	SF	2.00	4,000
Re-grade site to be ready for site development	2,000	SF	3.00	6,000
Site excavation to accommodate new storefront, allow 2000 SF	593	CY	20.00	11,852
Remove existing shrubs / trees	1	LS	2,500.00	2,500

96,407

15. Site Paving, Structures & Landscaping

0

16. Utilities on Site

Mechanical

Chilled water - supply & return: protect-in-place	1	LS	5,000.00	5,000
---	---	----	----------	-------

**Common Mall and Bookstore Renovation and Enhancement
 Lower Level - Career Center/Card Office/Elevator Lobby (Option 1)
 Riverside, California**

**Conceptual Cost Plan
 July 5, 2011
 016-08088.110**

<i>Item Description</i>	<i>Quantity</i>	<i>Unit</i>	<i>Rate</i>	<i>Total</i>
Water mains, domestic cold and fire: protect-in-place	1	LS	2,500.00	2,500
Sanitary sewer: protect-in place	1	LS	2,000.00	2,000
Natural gas: protect-in-place	1	LS	1,500.00	1,500
Electrical				
Mains power: protect-in-place, including root barriers	1	LS	5,000.00	5,000
Telecommunications/signals				n/a
				16,000

UPPER LEVEL - BOOKSTORE (OPTION 1) AREAS & CONTROL QUANTITIES

Areas

	SF	SF	SF
Enclosed Areas			
Upper Level - Bookstore (Option 1)	14,575		
SUBTOTAL, Enclosed Area		<hr/> 14,575	
 TOTAL GROSS FLOOR AREA			<hr/> 14,575

UPPER LEVEL - BOOKSTORE (OPTION 1) COMPONENT SUMMARY

	Gross Area: 14,575 SF		
		\$/SF	\$x1,000
1. Foundations		0.00	0
2. Vertical Structure		1.90	28
3. Floor & Roof Structures		2.27	33
4. Exterior Cladding		17.38	253
5. Roofing, Waterproofing & Skylights		1.15	17
Shell (1-5)		22.68	331
6. Interior Partitions, Doors & Glazing		4.36	64
7. Floor, Wall & Ceiling Finishes		12.78	186
Interiors (6-7)		17.15	250
8. Function Equipment & Specialties		1.00	15
9. Stairs & Vertical Transportation		4.94	72
Equipment & Vertical Transportation (8-9)		5.94	87
10. Plumbing Systems		0.00	0
11. Heating, Ventilating & Air Conditioning		5.20	76
12. Electric Lighting, Power & Communications		5.71	83
13. Fire Protection Systems		0.34	5
Mechanical & Electrical (10-13)		11.26	164
Total Building Construction (1-13)		57.03	831
14. Site Preparation & Demolition		5.73	84
15. Site Paving, Structures & Landscaping		0.00	0
16. Utilities on Site		0.00	0
Total Site Construction (14-16)		5.73	84
TOTAL BUILDING & SITE (1-16)		62.76	915
General Conditions	10.50%	6.59	96
Contractor's Overhead & Profit or Fee	4.00%	2.74	40
PLANNED CONSTRUCTION COST	July 2011	72.09	1,051
Contingency for Development of Design	13.00%	9.40	137
Escalation to Start Date (June 2013)	3.13%	2.54	37
RECOMMENDED BUDGET	June 2013	84.03	1,225

<i>Item Description</i>	<i>Quantity</i>	<i>Unit</i>	<i>Rate</i>	<i>Total</i>
1. Foundations				
No work is anticipated				0
2. Vertical Structure				
Columns and pilasters				
Tube or pipe steel columns	70	LF	150.00	10,500
Miscellaneous				
Jamb reinforcing at existing CMU wall	425	LB	5.00	2,125
Allowance for strengthening existing shear wall	1	LS	15,000.00	15,000
				27,625
3. Floor and Roof Structure				
Suspended floors				
Steel wide flange beam	24	LF	170.00	4,080
Steel tube or pipe beam	30	LF	190.00	5,700
Metal deck, 2" thick with light weight concrete infill, 3 1/4" thick (5 1/4" total thickness)	360	SF	11.00	3,960
Roofs				
Steel wide flange beam	42	LF	170.00	7,140
Metal deck, 2" thick	360	SF	6.00	2,160
Miscellaneous				
Framing and blocking	1	LS	10,000.00	10,000
				33,040
4. Exterior Cladding				
Interior finish of exterior wall				
Patch, repair and paint as necessary existing gypsum board lining	11,116	SF	3.50	38,906
Windows, glazing and louvers				
Aluminum framed curtain wall system	602	SF	100.00	60,200
Connect existing wall to new curtain wall system	28	LF	65.00	1,820

<i>Item Description</i>	<i>Quantity</i>	<i>Unit</i>	<i>Rate</i>	<i>Total</i>
Fascias, bands, sunscreens and trim				
Perforated metal panel screens including metal lightweight frame support; South and East	996	SF	45.00	44,820
Perforated metal panel screens including metal lightweight frame support; North and East	662	SF	45.00	29,790
Perforated metal panel screens including metal lightweight frame support; above Entry Lobby	616	SF	45.00	27,720
Allowance for signage graphics - support and lighting	1	LS	50,000.00	50,000
				253,256

5. Roofing, Waterproofing & Skylights

Insulation				
Rigid board insulation	360	SF	3.85	1,386
Roof covering				
Membrane roofing	360	SF	10.00	3,600
Patch and repair existing roof finish after installation of new skylight	132	SF	8.00	1,056
Roofing upstands and sheet metal				
Flashing and trim, roof specialties and accessories	1	LS	3,000.00	3,000
Rooflights				
Skylight, 3' x 8'	3	EA	2,400.00	7,200
Caulking and sealants				
Miscellaneous caulking and sealants	360	SF	1.25	450
				16,692

6. Interior Partitions, Doors & Glazing

Partition framing and cores				
Make good, patch and repair existing partition	420	SF	5.00	2,100
Wall framing including metal stud, batt insulation and gypsum board lining to both sides and paint finish	700	SF	13.40	9,380
Shaft wall framing including metal stud, batt insulation and gypsum board lining to both sides and paint finish - elevator shaft	476	SF	14.90	7,092

<i>Item Description</i>	<i>Quantity</i>	<i>Unit</i>	<i>Rate</i>	<i>Total</i>
Interior doors, frames and hardware Security metal gates	6	EA	7,500.00	45,000
				63,572

7. Floor, Wall & Ceiling Finishes

Floors including base				
Screed leveling to existing slab to receive new floor finish	14,215	SF	3.00	42,645
Stone tile to Entry lobby and Passageway	1,420	SF	16.00	22,720
Carpet tile to Retail spaces 1, 2 and 3	12,795	SF	4.25	54,379
Stone tile to elevator lobby	486	SF	16.00	7,776
Ceilings				
ACT ceiling generally	14,701	SF	4.00	58,804
				186,324

8. Function Equipment & Specialties

General building specialties				
Fire extinguisher, cabinets, code, directional and room identification, signage	14,575	SF	1.00	14,575
				14,575

9. Stairs & Vertical Transportation

Staircase flights - floor to floor				
Interior staircase, metal pan stair risers with concrete infill including landing, guardrail / handrail and stone tile finish 1 FLT	1	EA	27,000.00	27,000
Elevator				
Hydraulic passenger elevator, 1 stop	1	EA	45,000.00	45,000
				72,000

<i>Item Description</i>	<i>Quantity</i>	<i>Unit</i>	<i>Rate</i>	<i>Total</i>
10. Plumbing Systems				
Sanitary fixtures and local connection pipework - motion activated flushing valves				existing
Sanitary waste, vent and service pipework Floor drains and sinks, < = 6", complete with connection pipework, trap primers				existing
Surface water drainage Roof & overflow drains, < = 6",				existing
				0
11. Heating, Ventilation & Air Conditioning				
Piping, fittings, valves and insulation HHW pipework, fittings, < 3"	180	LF	30.00	5,400
Valves and specialties	1	LS	1,500.00	1,500
Insulation	180	LF	8.50	1,530
Air handing equipment VAV boxes with reheat coils	3	EA	875.00	2,625
Air distribution and return Galvanized sheet metal ductwork	3,000	LB	9.50	28,500
Flexible ductwork	500	LF	7.50	3,750
Dampers Volume	100	EA	45.00	4,500
Fire/smoke				n/a
Insulation	2,000	SF	4.00	8,000
Diffusers, registers and grilles	2,000	SF	2.00	4,000
Controls and instrumentation - Allerton Direct digital energy management system - including CO2 monitoring	1	LS	10,000.00	10,000
Test and balance air systems Including testing of existing systems	24	HR	105.00	2,520
Unit ventilation/exhaust fans General exhaust				existing

<i>Item Description</i>	<i>Quantity</i>	<i>Unit</i>	<i>Rate</i>	<i>Total</i>
Trade demolition	1	LS	3,500.00	3,500
				75,825

12. Electrical Lighting, Power & Communication

Machine and equipment power				
Connections and switches, including conduit and cable				
Elevator power	1	LS	12,750.00	12,750
Miscellaneous connections, < 225 AM - including specialty, F/S dampers, BMS power, fire, IT and security systems	1	LS	2,500.00	2,500
User convenience power				
Receptacles, including conduit and cable	2,000	SF	4.50	9,000
Lighting				
Fixtures/switches, including conduit and cable	2,000	SF	15.00	30,000
Lighting and power specialties				
Lighting control - daylight dimming	2,000	SF	2.50	5,000
Telephone and communications				
Telephone/data - horizontal cabling, POS outlets & WAPs	2,000	SF	6.00	12,000
Alarm and security				
Fire alarm systems				
Stations/devices, including conduit and cable	2,000	SF	4.00	8,000
Security - access control/motion sensors only	2,000	SF	2.00	4,000
				83,250

13. Fire Protection Systems

Fire protection				
Automatic wet fire sprinklers - reconfigure existing lay-outs	2,000	GSF	2.50	5,000
				5,000

<i>Item Description</i>	<i>Quantity</i>	<i>Unit</i>	<i>Rate</i>	<i>Total</i>
14. Site Preparation & Building Demolition				
Selective demolition and removal				
Take down and remove existing interior partition	327	LF	20.00	6,540
Take down and remove existing door	8	EA	150.00	1,200
Take up and remove existing floor finish	14,215	SF	1.85	26,298
Take down and remove existing ceiling finish	14,215	SF	2.00	28,430
Take down and remove fixed cabinetry	315	LF	28.00	8,820
Take down and remove existing book detection opening	2	EA	300.00	600
Create opening for new interior window	4	EA	750.00	3,000
Carefully take down and remove portion of exterior wall	392	SF	10.00	3,920
Take down and remove existing external door, double leaf	1	EA	200.00	200
Create opening on roof structure and finish for new skylight, 3' x 8'	3	EA	1,500.00	4,500
				83,508

15. Site Paving, Structures & Landscaping

0

16. Utilities on Site

0

SITWORK SUMMARY

	Gross Floor Area	\$ / SF	\$x1,000
Zone A	12,800 SF	35.23	451
Zone B	12,000 SF	30.07	361
Zone C	8,800 SF	21.51	189
Zone D	9,600 SF	30.26	291
Zone E	18,500 SF	28.47	527
Zone J	20,000 SF	39.61	792
Zone L	2,930 SF	24.90	73
TOTAL Sitework Construction	June 2013		2,683

	Quantity	Unit	Rate	Total
Zone A - 12,800 SF				
Site protective				
Allow for erosion control and site protective	1	LS	4,000.00	4,000
Site clearing and grading				
General site clearing	12,800	SF	1.00	12,800
Fell and remove trees, pear trees - 12 EA	1	LS	3,600.00	3,600
Rough grading	12,800	SF	1.00	12,800
Paving and surfacing				
Vehicle / pedestrian precast concrete pavers	2,300	SF	12.00	27,600
Site structures				
Concrete stepped seat wall	550	LF	200.00	110,000
Site furnishings				
Custom benches	37	EA	1,500.00	55,500
Landscaping				
Soil preparation including grading and topsoil	10,500	SF	1.00	10,500
Turf / groundcover on sycamore mound	2,000	SF	2.75	5,500
Turf / groundcover and / or decomposed granite	8,500	SF	3.00	25,500
Shrubs, 5 gallon	468	EA	25.00	11,700
Irrigation system				
Reconfigure / repair existing irrigation for new planting area	10,500	SF	1.85	19,425
Site drainage including SWPP	12,800	SF	1.85	23,680
Site electrical - lighting, power & low-voltage systems	12,800	SF	2.00	25,600
Markups	29.49	%	348,205.00	102,683
				450,888

Zone B - 12,000 SF

Site protective				
Allow for erosion control and site protective	1	LS	4,000.00	4,000

	Quantity	Unit	Rate	Total
Site clearing and grading				
General site clearing	12,000	SF	1.00	12,000
Fell and remove trees, pear trees - 10 EA	1	LS	3,000.00	3,000
Rough grading	12,000	SF	1.00	12,000
Paving and surfacing				
Vehicle / pedestrian precast concrete pavers	12,000	SF	11.00	132,000
Site furnishings				
Tree grate	18	EA	1,800.00	32,400
Landscaping				
Soil preparation including grading and topsoil for new trees	1	LS	8,000.00	8,000
Trees, 60" box	18	EA	2,000.00	36,000
Irrigation system				
Reconfigure / repair existing irrigation for isolated trees	18	EA	200.00	3,600
Site drainage including SWPP	12,000	SF	1.85	22,200
Site electrical - lighting, power & low-voltage systems	12,000	SF	2.00	24,000
Markups	29.49	%	243,000.00	71,659
				360,859

Zone C - 8,800 SF

Site protective				
Allow for erosion control and site protective	1	LS	2,600.00	2,600
Site clearing and grading				
General site clearing	8,800	SF	1.00	8,800
Fell and remove trees, pear trees - 10 EA	1	LS	3,000.00	3,000
Rough grading	8,800	SF	1.00	8,800
Paving and surfacing				
Vehicle / pedestrian precast concrete pavers	8,800	SF	11.00	96,800
Site drainage including SWPP	8,800	SF	1.85	16,280

	<i>Quantity</i>	<i>Unit</i>	<i>Rate</i>	<i>Total</i>
Site electrical - lighting, power & low-voltage systems	8,800	SF	2.00	17,600
Markups	29.49	%	120,000.00	35,387
				189,267

Zone D - 9,600 SF

Site protective				
Allow for erosion control and site protective	1	LS	2,900.00	2,900
Site clearing and grading				
General site clearing	9,600	SF	1.00	9,600
Fell and remove trees, allow	1	LS	2,500.00	2,500
Rough grading	9,600	SF	1.00	9,600
Paving and surfacing				
Vehicle / pedestrian precast concrete pavers	8,800	SF	12.00	105,600
Site furnishings				
Custom benches	14	EA	1,500.00	21,000
Landscaping				
Soil preparation including grading and topsoil for new trees	1	LS	4,000.00	4,000
Trees, 60" box	16	EA	2,000.00	32,000
Shrubs, 1 gallon	289	EA	15.00	4,335
Irrigation system				
Reconfigure / repair existing irrigation for isolated trees	16	EA	200.00	3,200
Reconfigure / repair existing irrigation for shrubs area	576	SF	1.85	1,066
Site drainage including SWPP	9,600	SF	1.85	17,760
Site electrical - lighting, power & low-voltage systems	9,600	SF	2.00	19,200
Markups	29.49	%	195,800.60	57,740
				290,501

	<i>Quantity</i>	<i>Unit</i>	<i>Rate</i>	<i>Total</i>
<u>Zone E - 18,500 SF</u>				
Site protective				
Allow for erosion control and site protective	1	LS	5,500.00	5,500
Site clearing and grading				
General site clearing	18,500	SF	1.00	18,500
Fell and remove trees, pear trees - 17 EA	1	LS	5,100.00	5,100
Rough grading	18,500	SF	1.00	18,500
Paving and surfacing				
Vehicle / pedestrian precast concrete pavers	18,500	SF	12.00	222,000
Site structures				
Custom concrete seat walls	4	EA	2,000.00	8,000
Site furnishings				
Tree grate	13	EA	1,800.00	23,400
Custom benches	4	EA	1,500.00	6,000
Landscaping				
Soil preparation including grading and topsoil	1	LS	6,000.00	6,000
Trees, 60" box	13	EA	1,800.00	23,400
Shrubs, 5 gallon	41	EA	25.00	1,025
Irrigation system				
Reconfigure / repair existing irrigation for new planting area	13	EA	200.00	2,600
Site drainage including SWPP	18,500	SF	1.85	34,225
Site electrical - lighting, power & low-voltage systems	18,500	SF	2.00	37,000
Markups	33.93	%	340,025.00	115,364
				526,614

Zone J - 20,000 SF

Site protective				
Allow for erosion control and site protective	1	LS	7,000.00	7,000
Site clearing and grading				

**Common Mall and Bookstore Renovation and Enhancement
Sitework
Riverside, California**

**Conceptual Cost Plan
July 5, 2011
016-08088.110**

	Quantity	Unit	Rate	Total
General site clearing	20,000	SF	1.25	25,000
Rough grading	20,000	SF	1.00	20,000
Paving and surfacing				
Vehicle / pedestrian precast concrete pavers	11,000	SF	12.00	132,000
Site structures				
Custom concrete stepped seat walls, at triangle	750	LF	250.00	187,500
Concrete seat wall, at triangle bookstore	400	LF	200.00	80,000
Landscaping				
Soil preparation including grading and topsoil	9,250	SF	1.50	13,875
Shrubs, 5 gallon	454	EA	25.00	11,350
Turf	4,400	SF	1.20	5,280
Turf, at triangle	3,200	SF	1.20	3,840
Irrigation system				
Reconfigure / repair existing irrigation for new planting area	9,250	SF	1.85	17,113
Site drainage including SWPP	23,000	SF	1.85	42,550
Site electrical - lighting, power & low-voltage systems	23,000	SF	2.00	46,000
Markups	33.93	%	591,507.50	200,687
				792,194

Zone L - 3,000 SF

Site protective				
Allow for erosion control and site protective	1	LS	1,000.00	1,000
Site clearing and grading				
General site clearing	3,000	SF	1.00	3,000
Rough grading	3,000	SF	1.00	3,000
Fell and remove trees, pear trees - 5 EA	1	LS	2,500.00	2,500
Paving and surfacing				
Vehicle / pedestrian precast concrete pavers	200	SF	12.00	2,400

	<i>Quantity</i>	<i>Unit</i>	<i>Rate</i>	<i>Total</i>
Site furnishings				
Tree grate	4	EA	1,800.00	7,200
Custom benches, U-shaped	3	EA	1,700.00	5,100
Landscaping				
Soil preparation including grading and topsoil	1,000	SF	1.50	1,500
Trees, 60" box	5	EA	2,000.00	10,000
Shrubs, 5 gallon	250	EA	25.00	6,250
Irrigation system				
Reconfigure / repair existing irrigation for new planting area	1,000	SF	1.85	1,850
Reconfigure / repair existing irrigation for isolated tree	5	EA	200.00	1,000
Site drainage including SWPP	3,000	SF	1.85	5,550
Site electrical - lighting, power & low-voltage systems	3,000	SF	2.00	6,000
Markups	29.49	%	56,350.00	16,617
				72,967

Quantity Unit Rate Total

Estimates of Additional Funding to be provided by Others, outside this project scope

1. Career Center Funding

A. Career Center FF&E

Career Center FF& E (include markups and softcosts)	6,830	SF	22.80	155,724
				155,724

B. Gas relocation and lowering windows at the Career Center

Selective demolition, removal and site preparation

Create window opening in concrete wall to accommodate larger storefront window - North West	309	SF	35.00	10,806
Clear existing site structures, existing paving and landscape berm	3,000	SF	2.00	6,000
Re-grade site to be ready for site development	3,000	SF	3.00	9,000
Site excavation to accommodate new storefront, allow 3000 SF	889	CY	20.00	17,778
Remove existing Fir trees	2	EA	1,500.00	3,000
Remove existing shrubs	1	LS	3,000.00	3,000

Windows, glazing and louvers

Aluminum framed storefront window - NW	309	SF	85.00	26,244
Patch, repair and paint as necessary existing gypsum board lining surrounding	500	SF	2.00	1,000

Natural gas

Underground pipework, fittings, < = 3"	400	LF	65.00	26,000
Valves & specialties	1	LS	8,750.00	8,750
Connections to existing	1	LS	3,500.00	3,500

Markups	33.93	%	115,077.78	39,044
Soft cost	20.00	%	154,121.39	30,824

184,946

2. Parking Lot 19 Funding

A. Service gates

Paving

Patch and repair service drive paving	4,611	SF	2.55	11,758
---------------------------------------	-------	----	------	--------

	<i>Quantity</i>	<i>Unit</i>	<i>Rate</i>	<i>Total</i>
Fence and gates				
Metal fence with perforated metal privacy screen, 60% opaque, 8' high	100	LF	150.00	15,000
Sliding, automatic gate, 12' wide	2	EA	8,000.00	16,000
Key card	4	EA	800.00	3,200
Markups	33.93	%	45,958.05	15,593
Soft cost	20.00	%	61,550.71	12,310
				73,861

B. Ramp

Site preparation				
General site clearing	4,000	SF	2.00	8,000
Fine grade	4,000	SF	0.50	2,000
Site structures				
Pedestrian ramp	4,000	SF	20.00	80,000
Concrete retaining wall, allow 150' long x 3' high, 6" thick	450	SF	40.00	18,000
Concrete steps	30	LF	50.00	1,500
Handrail to steps	10	LF	150.00	1,500
Site drainage				
New trench drain re ramp run-off	25	LF	175.00	4,375
New area drains or trench drains to capture runoff from the ramp and new plaza	5	EA	5,000.00	25,000
Markups	33.93	%	140,375.00	47,626
Soft cost	20.00	%	188,001.45	37,600
				225,602

3. Alternates

A. Trellis canopy

Canopy including structure support and finish as specified				
Trellis from bookstore to HUB building, allow 10' wide	1,100	SF	100.00	110,000
Trellis in front of Coffee Bean, allow 10' wide	750	SF	85.50	64,125
Markups	33.93	%	174,125.00	59,077
Soft cost	20.00	%	233,202.16	46,640
				279,843

	<i>Quantity</i>	<i>Unit</i>	<i>Rate</i>	<i>Total</i>
B. Additional HUB signage and pylon				
Additional HUB signage and pylon (include mai	1	LS	199,200.00	199,200
				<hr/>
				199,200

10. IMPLEMENTATION



PROJECT SCHEDULE:

The preliminary project schedule includes the following:

- PPG (Project Planning Guide) approvals
Summer 2011
- Design and Construction Documents completion
March 2012
- Bid period March-April 2012
- Construction completion February 2013

* Dates are approximate

11. APPENDIX



TASK AND DELIVERABLES CHART**CAMPUS SUPPORTING DOCUMENTS:**

11/03/2010	Original Information/Meeting Handouts from UCR
------------	--

MEETING NOTES:

09/23/2010	PMT Meeting 1
10/27 - 10/28/2010	Committee Meeting 1
11/30/2010	PMT Meeting 2
01/13/2011	PMT Meeting 3
02/01/2011	DRB Presentation
03/29/2011	Cost Estimate Meeting

UCR COMMONS MALL AND BOOKSTORE RENOVATION AND ENHANCEMENT

DATE	TASK	TASK AND DELIVERABLES
9/13/2010	TASK #1	DATA COLLECTION & SITE INFORMATION REVIEW (PROVIDED BY UCR) <u>Scope:</u> Gather existing documentation for site and building <u>Deliverables:</u> Set up FTP site; file tracker
9/20/2010	TASK #2	PMT KICKOFF MEETING AT UCR <u>Scope:</u> Visioning; Establish project boundaries; Begin site analysis. <u>Deliverables:</u> Meeting Notes including marked up site plan showing proposed boundaries of work
10/11/2010	TASK #3	2 DAYS PMT, COMMITTEE AND FOCUS MEETINGS AT UCR (SWA AND RSM 1 DAY) <u>Scope:</u> PMT/Committee meetings; 6 Focus Group Meetings; Preliminary FPA team design ideas; LEED discussion. Begin concept design alternatives <u>Deliverables:</u> Meeting Notes including sketches of on-site initial concepts
10/24/2010	TASK #4	DEVELOP OPTIONS/MENU CONCEPTS <u>Scope:</u> Develop preliminary site options, bookstore building layouts, discussion with MEP consultants, storefront design for Latitude; PMT GoToMeeting <u>Deliverables:</u> Concept sketchpak; Telcon Notes
1/13/2011	TASK #5	1 DAY MEETING AT UCR FOR PREFERRED CONCEPTS (FPA and SWA) <u>Scope:</u> PMT/Committee selection of preferred bookstore building layouts, Latitude storefront and site options. Consultant site walkthrough followed by discussion of systems and sustainability <u>Deliverables:</u> Redmarked concepts for Master Plan; updated LEED chart; Meeting Notes
1/17/2011 -- 1/28/2011	TASK #6	DEVELOP MASTER PLAN SCOPE DIAGRAMS FOR DRB <u>Scope:</u> Preferred DPP scope not yet selected. Prepare new diagrams for DRB Consultants prepare draft narratives for FPA; PMT Go-To-Meeting to review draft DRB materials <u>Deliverables:</u> New presentation materials; Telcon Notes
2/1/2011	TASK #7	1 DAY MEETING AT UCR; PRESENTATION TO DRB 12/7/10 (SWA 1/2 DAY) <u>Scope:</u> DRB presentation; PMT debrief on DRB and plans for upcoming CPAC meeting <u>Deliverables:</u> DRB presentation materials; 94-slide powerpoint
2/14/2011	TASK #8	REVIEW AND INCORPORATE BOOKSTORE INTERIORS <u>Scope:</u> Review bookstore interior layouts submitted by client. Develop and update existing master plan sketches for bookstore building <u>Deliverables:</u> Comments on interior layout for client and cost estimator
3/01/2011-- 3/25/2011	TASK #9	PREPARE DRAFT MASTER PLAN COST ESTIMATE <u>Scope:</u> Revise and update technical narratives to include two options for bookstore; 12 landscape zones with detailed matrix for pricing; concept signage package; and FF&E allowances. Consultant review of draft cost estimate <u>Deliverables:</u> Detailed exhibits for "kit of parts" cost estimate, including draft cost estimate and technical narratives; 11" x 17" drawing exhibits by discipline
3/29/2011	TASK #10	1/2 DAY MEETING AT UCR FOR DRAFT COST ESTIMATE REVIEW (FPA,SWA) <u>Scope:</u> Present draft cost estimate and options for DPP scope <u>Deliverables:</u> Meeting Minutes; requested breakdowns in cost estimate

UCR COMMONS MALL AND BOOKSTORE RENOVATION AND ENHANCEMENT

DATE	TASK	TASK AND DELIVERABLES CONTINUED
4/4/2011	TASK #11	DEVELOP PREFERRED DPP SCHEME AND UPDATE MASTER PLAN SKETCHES <u>Scope:</u> Begin Bookstore Space Program and Area Data Sheets; Develop preferred DPP concept and master plan sketches <u>Deliverables:</u> Preliminary Space Program and Area Data Sheets
4/11/2011	TASK #12	DRAFT DPP SECTIONS AND CPAC EXHIBITS <u>Scope:</u> Discuss DPP illustrations, draft CPAC materials and cost estimate breakdowns, and Clients preliminary project schedule <u>Deliverables:</u> PMT Go-To-Meeting to review draft CPAC materials; updated space program and Area Data Sheets; draft Schedule; Telcon Notes
4/25/2011	TASK #13	1 DAY MEETING AT UCR; PRESENTATION TO CPAC (SWA AND RSM-1/2 DAY) <u>Scope:</u> CPAC presentation; Review CPAC comments, DPP scope with PMT/Committee <u>Deliverables:</u> CPAC presentation materials; Meeting Notes
4/25/2011-- 5/13/2011	TASK #14	UPDATE DOCUMENTS FOR 95% DPP DRAFT <u>Scope:</u> Complete DPP draft with design exhibits; PMT telcon on updated cost estimate. <u>Deliverables:</u> Updated cost estimate; final DPP draft; Telcon Notes
7/1/2011	TASK #15	FINAL DPP <u>Scope:</u> Receive all comments from UCR; incorporate final changes to document and cost estimate. <u>Deliverables:</u> Final DPP

UCR: Commons Mall and Bookstore Renovation and Enhancement DPP
Original Information / Meeting Handouts (Last updated 11.3.2010)

The following table contains a list of materials distributed or received at site visit, via emails or other meetings. The purpose of the document is to manage the flow of materials to and from the consultant.

Date Requested	Source	Document Description	Distribution Date	Transmitted
9.7.2010	Capital Planning	<ul style="list-style-type: none"> • Site plan (CAD) • Building plans for: <ul style="list-style-type: none"> ○ Bookstore ○ HUB, Activities Bldg., HUB Coffee ○ Surge Bldg. ○ Lecture Bldg. • ADA Survey (Bookstore) • Existing program for Career Center • Elevation data for buildings and plaza spaces around project area • UCR Campus Design Guidelines (reference document for landscape standards) • As-builts for: <ul style="list-style-type: none"> ○ Bookstore/Commons Mall Site ○ HUB 	9.16.2010 9.16.2010	FTP (FP) FTP (FP)
9.7.2010	ODC	<ul style="list-style-type: none"> • Utility information including capacity restrictions, onsite water management 	9.16.2010 9.16.2010	DVD disk DVD disk
9.7.2010	ODC, CPP, PP	<ul style="list-style-type: none"> • Select data from Cheryl Garner • DRAFT Dining Master Plan Report 	In progress	--
9.13.2010	Dining	<ul style="list-style-type: none"> • Multi-modal Transportation Management Study • First floor plans for: <ul style="list-style-type: none"> ○ Pierce ○ Bourns ○ MS&E 	9.22.2010 In progress	email --
9.23.2010	CPP	<ul style="list-style-type: none"> • Fire lanes on campus (In progress version) • Bike lanes around campus • Test fit for Career Center (Study) • Aerial imagery of study area • Site plan (CAD) – UPDATED TO INCL. MS&E 	By hand 9.29.2010 9.29.2010 9.29.2010 9.29.2010	10.27.2010 FTP (FP) FTP (FP) FTP (FP) FTP (FP)
9.23.2010	Student Affairs	<ul style="list-style-type: none"> • Survey of bookstore retail behavior 	9.29.2010	FTP (FP)

continued

MEETING NOTES

Issue Date:	September 27, 2010	Present:	UCR: Jim Sandoval; Danny Kim; Don Caskey; Darius Maroufkhani; Tim Ralston; Nita Bullock; Uma Ramasubramanian
Meeting Date:	September 23, 2010		
Project:	UCR Commons Mall and Bookstore Renovation and Enhancement DPP		
Project No.:	1034.10	FPA:	Avery Taylor Moore; Steve Lovell
Re:	PMT Meeting 1	SWA:	David Berkson; Amy Oliver
Location:	HUB 376-UCR		
Prepared By:	Avery Taylor Moore	cc:	

Notes:

1. INTRODUCTIONS: Participants introduced themselves and their project roles:

UCR's Project Management Team:

- Jim Sandoval, Vice Chancellor for Student Affairs
- Danny Kim, Assistant Vice Chancellor for Student Affairs; oversees the HUB; Campus Store and Career Center, among others.
- Tim Ralston, Associate Vice Chancellor for Capital and Physical Planning
- Nita Bullock, Project Manager, Capital and Physical Planning; Campus Landscape Architect; primary point of contact
- Don Kaskey, Associate Vice Chancellor for Design and Construction; Campus Architect
- Darius Maroufkhani, Project Manager, Design and Construction; Project Manager for the HUB
- Uma Ramasubramanian, Senior Planner, Capital and Physical Planning

Field Paoli's architectural team:

- Avery Taylor Moore, Principal in Charge
- Steve Lovell, Design Principal and Project Manager for DPP

SWA's landscape team:

- David Berkson, Principal in Charge
- Amy Oliver, Associate and Project Manager

2. FIRST IMPRESSIONS FROM THE DESIGN TEAM:

Steve Lovell reviewed some of the PowerPoint from the team interview which summarized Field Paoli's initial project impressions and several possible design directions for the DPP and future phases of work. Concepts are to:

- Enliven the Commons Mall with distinct activity and landscape zones that are integrated with the HUB and other building uses along the Mall perimeter
- Address the need for stronger retailing presence and shaded hang-out space
- Revitalize the Bookstore with improved entrance on Commons Mall, new retailing presence along the north façade and Lower Plaza frontage, and attention to future shopping patterns and needs
- Make the Lower Plaza its own destination with seating and food service
- Extend the HUB identity to North Campus Drive
- Consider a new, future phase building at Commons Mall to strengthen and better define both the Mall and the Hub Piazza

Meeting Notes

PMT Meeting 1

3. INITIAL PMT GOALS FOR THE PROJECT:

Don Caskey:

- Felt that Field Paoli understood what they are trying to do: to strengthen the connectivity of the whole area.
- One of the successes of the HUB is the environmental graphics that took it beyond “place” to a place people wanted to be. Goal is to extend area and tie it together.
- An obstacle is the service drive which functions as a back alley with safety issues.
- How to bring people through the Lower Plaza and up through the Bookstore is critical.
- Creating a sky lit Galleria, full of light, over central stair could be a solution, but gets into FTEs for store.
- Need to define the edges of the project. As an Urban Design graduate, Don wants to get rid of edges and embrace the buildings around the perimeter, more than just the building entrances.
- There is a “fuzzy” footprint with engineering and the boundaries for the DPP; plan is for HUB to take over maintenance of the DPP defined area with the exception that the larger trees may be maintained by Physical Plant.
- Commons Mall has to have an activity, a purpose that competes with the Piazza activities below.

Darius Maroufkhani:

- Loved slide show with the sketches and trees.
- Piazza was designed to be an activity space with HUB upper floor decks sharing the activity below; there is some problem with too much sun [and a need for more shade]
- The end of the Commons Mall at North Campus Drive is “dead”; a beacon or other symbol can provide a sense of arrival.
- People coming from the new engineering building will cross a bridge from the second floor to reach the sidewalk at North Campus Drive (the first floor is below street level, although the site is excavated for daylight; stormwater is managed with large underground culverts)
- The Lower Plaza is used a lot due to the Surge Building.

Uma Ramasubramanian:

- Need to understand the attitude toward the street since North Campus Drive is used only for service or special permit vehicles.
- Make the Lower Plaza viable.
- Make the Commons Mall a precinct.
- Recognize the existing framework of campus Malls.
- Understand where technology is taking us and the attitude of students.

Jim Sandoval:

- Greatest pride over 22 years is the success of the HUB building and the fact that the project was student-driven.
- Wanted a world-class signature building. Campus was searching for a better sense of identity, and you know now that you are at a world-class institution.
- This project is Commons Expansion 2, addressing the programmatic loss in area when the HUB project was cut back.
- The Commons Mall walkway needs to integrate with the arches at Rivera Library; but it should be a different expression. Jim is going on record that he does not like the arches. [Don agreed that the campus has gone too far in another direction to go back to the arches.]
- Need more dining venues; dining at the HUB is not adequate.

Danny Kim:

- Need to expand the upper entrance to the Campus Store.
- Agreed with Field Paoli that the Rotunda is underutilized; it was originally designed to tie [aesthetically] to the old Commons Building.

Meeting Notes

PMT Meeting 1

- Likes the landscape photos in the Power Point interview. Believes they could work well for the Commons Mall.
- Working to create a robust, vibrant atmosphere. That is why there is music outside.
- At 20,000 students, UCR has critical mass to capitalize on.
- Concerned about the utility [service] road for safety.
- Need to activate the upper Commons Mall; there is no intended use now.
- Can relocate the new pylons if it works best with proposed DPP designs.

Tim Ralston:

- Welcomes the design opportunity to try to integrate the bookstore more effectively.
- There will be significant changes in student traffic coming from the Material Sciences and Engineering Building which will include 6 general assignment classrooms, 2 of which will have over 300 seats each.
- More traffic will come from the Glenmore II 800-bed residential complex [to the east], opening in 2013.
- Campus will have some 1st rate dining services under Cheryl Garner.

Nita Bullock:

- Excited about this project.
- Peripheries are wanting.
- Will have a 24-7 operation in this area and need to plan for it.
- Every time a new building goes up, traffic patterns will change.

4. DISCUSSION AND SITE WALK:

- Service Road: Delivery vehicles use the service road to cross the Commons Mall to service Pierce Hall. Darrius said there is a physical solution to separate Pierce deliveries, but it will take work. Don thinks it may be worth looking at for a future phase of work. The service drive is very dangerous; with uphill access, it is not easy to see people who pop out to use the cross walk to the Lower Plaza. New gates will be installed at the west side of the Lower Plaza crosswalk and the west side of the Bookstore entrance, requiring delivery vehicles to stop for gate opening, and preventing students from walking up the service drive. Parking Lot 19 is also being redesigned, and pedestrians will no longer be allowed to cross the lot to reach the service road entrance.
- Landscape Plans for Commons Mall: Don believes documentation may be in bits and pieces, associated with individual building designs: Pierce Hall, the old Commons Building, and the Bookstore built during the 60s; Bourns Hall built in the 90s; the Pierce Hall addition in the 2000s.
- Tree Survey: Nita said there is a campus arborist and there are on-campus rules about trees; specimen trees are in a database and memorial trees have plaques. But to Nita's knowledge, there is no arborist report or specific landscape plan for the Commons Mall.
- Irrigation: There is no reclaimed water used for landscaping on campus.
- Campus Store Renovation: Main purpose is to increase revenue. The vacant reprographics space has been looked at as a placeholder for a new dining venue, but it could be annexed/opened into the store if there is a program need for it. Don likes the idea of an escalator in theory, but they are a maintenance headache, and there are none currently on campus so no service contract or history is in place.

Danny said that the existing textbooks space is large for the amount of sales, and a larger career center footprint can be accommodated [on both sides of the existing stair]. There is one storage space off campus for bookstore inventory. The Campus Store operates a books exchange and textbook leasing online. Tradebooks sales are shrinking; plan to use the space for more gift books, campus authors, an Apple kiosk [Apple has said they will help with the design]

Meeting Notes

PMT Meeting 1

Tim said there was an internal study several months ago to test fit the Career Center; FPA asked for a copy. Nita said there was a former study to put a Peets Coffee at the Lower Plaza level but that study is not operative.

- Other retail places: Danny would like a new storefront identity for Latitude which does not have enough presence for students to realize it is an entertainment venue. Subway will be opening in the retail space north of the Coffee Bean and Tea Leaf adjacent to the service road and across from the bookstore's main entrance. There is a new 300 sf C-store and café opening at Engineering II.
- Commons Mall use: Expecting 8,000 students to attend opening day event with club booths, music, food. This is also the venue for the campus HEAT music festival with two stages, dance area, and 2 stages.
- Future building expansion: Darrius said it is important to position any new buildings so they do not block the iconic view to the carillon from the Commons Mall.
- Pedestrian connections to Commons Mall: From east, many students are coming from Parking Lot 13, Lothian, Glenmore II, and the Science Library.
- Campus growth: Don said that in March 2008, there were about 17,500 students. Currently, there are 21,000 students, representing a huge increase of 3,500 students in 2 ½ years.

5. DPP PROJECT PROGRAM:

- The campus is currently using an off campus ADA consultant.
- Students do not use the Commons Mall to enter Pierce or Bourne Halls; the primary building entrances are on the east side.
- Lot 19 is master planned for a future Art Gallery.
- Food Service: Resident students have been able to use their meal cards at the HUB, but food service is overutilized so card limits for HUB are being reduced to accommodate more use by off-campus students, faculty and administration. Don encouraged review of the Food Service Master Plan [not yet available].
- Satellite Bookstores and Bookstore Traffic: Danny said they had a store at University Village but it was not successful. Currently, he sees no need for a satellite. There is an uptick in sales to alumni. Lots of sweatshirt sales at move-in. The University theatre does bring some Riverside residents, but to the other side of campus. The Student Rec Center is going to expand and will bring more students and Riverside residents for games and events; mostly at night.
- DPP scope: Nita said the plan should provide a vision of where to go not a band air to the problem; continue to think big. Priority is an aesthetic direction for the Commons Mall to create student pride and a strong connection to the HUB.
- Don reiterated that there needs to be a vision for how students will pause and buy inside the store. Creating Place. Apparel may come first. HUB currently stays open until 10 pm; the Campus store is open M-F 8:30am to 6pm, and Saturdays from 10am to 3pm; closed Sunday.

6. DPP BUDGET AND SCHEDULE AND APPROVAL PROCESS:

- HUB governing board has to approve an authorization.
- Currently there is a \$500K authorization for this project; includes student fee contribution. Other funding sources will be tapped.
- DPP will need to get a governing board approval to move to next phase.

Meeting Notes

PMT Meeting 1

- DRB has 3 outside architects who are collaborative, and faculty representatives. There is a current vacancy for site development.

7. NEXT STEPS:

- Nita and Uma will track down as-builts for:
 - Pierce and Bourns Hall floor plans, and adjacent landscape if available
 - Surveys for other buildings along the Commons Mall
 - High res aerial photo of site
- FPA to draw DPP boundaries from PMT Meeting 1 and post of FTP site.

MEETING NOTES
UCR COMMONS MALL AND BOOKSTORE RENOVATION

Issue Date:	November 4, 2010	Present:
Meeting Date:	October 27-28, 2010	UCR/PMT: Jim Sandoval; Danny Kim; Don Caskey; Darius Maroufkhani; Tim Ralston; Nita Bullock; Ulma Ramasubramanian
Project:	UCR Commons Mall and Bookstore Renovation and Enhancement DPP	UCR / COMMITTEE: Scott Campbell, Director Bookstore; Cheryl Garner, Director Food Service; Randy Williams, Director Career Center; John Ganim, Academic Senate Representative; Joe Steinmeyer, Facility Manager HUB [for Todd Wingate]; John Faheem, ASUCR representative; Gary Coyne, GSA representative CAMPUS REPRESENTATIVES: Scott Corrin, Campus Fire Marshall; Earl LeVoss, Physical Plant Superintendent; Tos Ishida, Asst. Director Physical Plant and Grounds Department; John Freese, Campus Police; Nicole Seebach, student; Liliana Barcelo, student; Mike Delo, Director Transportation and Parking Services
Project No.:	1034.10	FPA: Avery Taylor Moore; Steve Lovell
Re:	Focus Group Meetings	SWA: David Berkson; Amy Oliver
Location:	HUB 302-UCR	RSM: Suzanne Redmond Schwartz
Prepared By:	Avery Taylor Moore	Cc:

DAY ONE: OCTOBER 27, 2010 through Focus Group 2

1. **NITA BULLOCK: SUMMARY OF STATED GOALS TO DATE:**
 - Explore opening of bookstore stair to enliven the space
 - Relocate computers to the upper floor
 - Move Career Center for better presentation and student traffic
 - Consider more food outlets at the lower plaza
 - Revitalize and repurpose the Commons Mall

2. **FPA TEAM: POWERPOINT PRESENTATION**
 - Avery showed existing conditions, with the Commons Mall open and undifferentiated; the Bookstore largely hidden from view on all sides; the Lower Plaza not activated; and the many level changes to improve and use to advantage.
 - Steve showed examples of successful retail/people places worldwide; explained the need to see into retail spaces, and to integrate outside and inside activities; and showed preliminary concepts for extending the Hub environment north to activate the Lower Plazas and North Campus Drive edge, and for activating the Commons Mall area including possible addition of a new building at the south edge.
 - David spoke of the merit of landscape heritage for this campus; the need to maintain the "larger view" of the entire campus plan; and using design to assist with drainage and express sustainability.
 - Suzanne spoke of extending the established graphics program; reinforcing the sense of pride; and moving from the "there there" of the HUB to the "where where" of the Bookstore which is not yet integrated.

3. **COMMITTEE MEMBER VISIONS AND GOALS FOR THE PROJECT:**
John Ganim, Academic Senate Representative:
 - Three main needs are: Shade, Places to sit, and Landscape; these are often the most difficult to fund and the hardest to justify

Meeting Notes

UCR Commons Mall and Bookstore Renovation and Enhancement DPP

Meeting Date: October 27-28, 2010

- The original Commons Building had a beautiful exterior with alcoves along the perimeter; it fit with the classical mid-century modern buildings on the rest of the campus
- The current HUB building is John Jerde plunked into the middle of a difficult campus setting
- The proposed design concepts are more like Rick Caruso, going for the experience of the space
- The bookstore is like a large airport, designed to zip right through. Campus was an automobile environment when it was built with its Soviet constructivist façade, you could drive in, run in, and drive away. The entrance was blind

Randy Williams, Director, Career Services Center:

- Visibility is the issue
- Signage will be important
- The existing facility does not work: 2 hallways and no meeting space
- Desire a corporate feel
- Looking for “sticking space”, where students will see center and walk in the door

Scott Campbell, Director, Campus Bookstore:

- Bookstore has an identity problem to solve; no one knows us
- People call us the Bookstore and the Campus Store
- Will have been in business 20 years this coming March; everything is dated, both interiors and exteriors
- Green glass and bronze glass were designed by the then campus architect
- We are 20 years behind the times

Joe Steinmeyer, Facility Manager, HUB:

- Todd wants openness to the Mall. Small carved-out spaces defeats other larger events
- Shade is a big concern
- Need increased power capabilities
- When HUB started, were not even thinking about the bookstore
- Top priority is to replace uneven concrete and irrigations at the Commons Mall; it is going to fail soon
- Lighting needs to be changed as well
- Pear trees provide some shade but non-sustainable; susceptible to blight
- Should define first phase of work now
- Proposed new building is too small; on hot and rainy days, HUB is overflowing with people
- Need to plan for the annual “Heat” concert event and for truck turning on the Commons Mall for other events

Cheryl Garner, Director, Food Services:

- Should look at the Masterplan for Dining
- Have not been successful in keeping people at the HUB after lunch period
- A lot of the success of this project will be because of development of exterior spaces
- Environment needs softness, shade, and a connectedness
- Currently no sense of contiguous flow
- Love idea of different scaled spaces and bringing it all together
- Students on this campus are very religious about the lunch hour; lines are long. No one bridges “the shoulder”; no robust dinner business
- (Randy: Does not eat at HUB; lines are too long.)
- Where restaurant stays open past lunch hours at one residential facility, the flow of students is better.
- Coffee Bean has cannibalized some of the HUB business
- Bytes, café at Bourn Hall, had a soft opening; cannibalizing is not yet evident
- Residential package includes Dining Dollars so HUB does not bring in new dollars when residential students use it. Pushing students to use residential facilities has opened up the HUB

Meeting Notes

UCR Commons Mall and Bookstore Renovation and Enhancement DPP

Meeting Date: October 27-28, 2010

- There is clearly a 4th meal component- late night. (Don: Has seen students shift their meals away from breakfast to three meals including late night)
- Looking at food trucks for some underserved areas of campus. Need to identify and capture a Pad at each location. First truck will be a Taco Fresca truck with food from a popular local restaurant
- Truck traffic often starts out strong and fizzles. We have not experienced this with a truck to date (Coffee Truck).
- Penciling profits is difficult with campus wages
- Would like to serve some healthier food. A+I (Aberdeen and Inverness) does have a make your own salad bar and staff go there
- (Randy: Lighting at night beckons students to food venues)
- 50% of HUB nighttime revenue is Dining Dollars. Latitude and Hub close at 10 pm during the school year
- Coffee Bean struggles during the weekend. Over 12 hours, took in \$400.

ADDED COMMENTS:

Don Caskey, Campus Architect:

- HUB is a signature building. OK if it is Jerde-esque
- Does not have any intimate space; exterior space is hot. Closest intimate space is the second floor patio with umbrellas. Overall, building is pretty bipartisan and hard-edged.
- Commons Mall as large open space is good for large events but not for every day use
- Commons Mall is the bridge; do not want to see hard graphics right up to the Bourns edge
- Pearl Street in Boulder is an example where people want to be
- Need a series of spaces, SHADE, where buildings are a backdrop to landscape
- Think of it as "Whatever we do at the Commons, is coming back to the HUB"
- For Bookstore, need to reprogram rather than rename; people could be taking language classes at all times of day

Darius Maroufkhani, Project Manager, Design and Construction, Project Manager for the HUB:

- This is a large urban design project with lots of edges
- Conflict of service road needs to be addressed
- Conflict with Heat" and what we are trying to do. (Danny: This is a one time annual event)

Joe Steinmeyer, Facility Manager, HUB:

- HUB is used from 8-9 am to 4am (food closes earlier)
- Currently use entire 2nd level of HUB

Tim Ralston, Assoc. VC Capital and Physical Planning:

- Transitions and level changes are important to resolve.

4. FOCUS GROUP 1: STUDENTS Lunch

John Faheem, Student Body Senator; ASUCR Exchange Committee; Undergraduate Admissions:

- Did not know what Comp UCR offered; now there once a day; cheapest prices anywhere; should be advertised widely. All students need ethernet cables and would come here to get them.
- Would have been good to move computers to where Subway is going to be located
- Apparel: Sales appear to be good. Don't offer class rings. [Scott: this is an order only item, for proper sizing]
- Textbooks: Students use Amazon.com or Velor.com which ships inexpensive books from Indonesia.
- Supplies: Most students go to Walmart or Kmart
- Latitude:
 - Hard to find.
 - Deal on chicken strips was great, and then the price on everything was raised.
 - Marketing is working; more freshmen playing video games
 - Sing for your Supper is very successful; two hour wait

Meeting Notes

UCR Commons Mall and Bookstore Renovation and Enhancement DPP

Meeting Date: October 27-28, 2010

- Hard to find food on campus under \$6.99
- University Village has double size hamburgers; likes salads and they are too expensive
- Goes to Graduate study lounge
- Also, everyone hangs out at the HUB outside
- Old construction staging area outside Coffee Bean --"the Bump"—needs to be improved
- Would like a Highlander statue for visitors
- Would like a "wow" water feature; one from the 70s was removed

Gary Coyne, GSA Representative, 5-year graduate student:

- Gifts: Grad students get on-line card for Mother's Day
- Never bought a backpack from store
- Did buy laptop; repairs not offered; 1 time/month, there is someone at shop or there is a referral repair service. Used to have GEEK Squad come in 1 time/week
- Visibly more students now on campus than in 5 years ago

Nicole Seebach and Liliana Barcelo: Sophomore students; sorority members:

- Vicki bought all textbooks 1st semester freshmen year; did not get enough for buyback so did not buy again
- If price is an issue, students rent online
- Commons Mall events
 - Wednesdays = Club time
 - Unity Week in Spring; no longer Greek Week, also includes other clubs; includes races, fundraising, points towards Game tickets, dance competition
 - Have to clean up and take down displays daily by 6 pm.
 - HEAT
 - 1 day event from 5-11 pm, coincides with start of basketball season
 - 3 stages. Last year: Rivera, south of Pierce on Carillon Mall and HUB Piazza
- Non-students come on campus and try to sell things on Commons Mall. They are very aggressive and do not take no for an answer [John Freeze: if students call dispatch, they will come and intervene]
- Would like to be able to use Dining \$ off hours
- Need a UCR MAP on light fixtures, not just the HUB floor plan

General Conversation:

- Spend more time here than they did as freshmen
- Meet where there is a destination
- Bikes are increasing but you can still walk everywhere. [Don: not many bike racks but those that exist are always full]
- Like Barn for concerts; also professors like to go there

5. FOCUS GROUP 2: CAMPUS LANDSCAPE, MAINTENANCE, FIRE MARSHALL, POLICE Site Walk

- Deliveries at Latitude and Bookstore
 - Sysco delivers every day
 - Traffic will increase with Subway
 - Armored truck services Bookstore daily
 - Private vehicles and vendors with passes also have access
 - Some vehicles back up roadway and others turn around on Commons
 - The new Beacon Sign will prevent some vehicles from turning at this location
 - Crosswalk needs to be redesigned to be accessible
- Deliveries to and from Pierce
 - To deliver from east side, would have to move Nitrogen tanks and resolve grade changes

Meeting Notes

UCR Commons Mall and Bookstore Renovation and Enhancement DPP

Meeting Date: October 27-28, 2010

- Utilities at Lower Plaza/Market Street
 - Need access for cranes to change AHUs at Surge building
 - Lighting at lower HUB is adequate
 - Students travels north-south up to 10 pm for classes

COMONS MALL

- Need 1 irrigation controller to re-link sprinklers. Commons Mall controller is at lower Hub, not convenient location
- Need to locate underground utilities and tunnels
- Need to provide fire access to west side of Bourns Hall; currently drive up service drive and across Commons Mall, then turn north. May be possible to come from east on south side of Bourns
- Also need to maintain service access to Pierce which currently comes across Commons Mall
- Need to look at parking master plan for Lot 13 and gate access proposed by university.

See Second Half of Meeting Notes for Focus Groups 3 through 5 and RECAP

**MEETING NOTES –SECOND HALF
UCR COMMONS MALL AND BOOKSTORE RENOVATION**

Issue Date: November 9, 2010	Present:
Meeting Date: October 27-28, 2010	UCR/PMT: Jim Sandoval; Danny Kim; Don Caskey; Darius Maroufkhani; Tim Ralston; Nita Bullock; Ulma Ramasubramanian
Project: UCR Commons Mall and Bookstore Renovation and Enhancement DPP	UCR / COMMITTEE: Scott Campbell, Director Bookstore; Cheryl Garner, Director Food Service; Randy Williams, Director Career Center; John Ganim, Academic Senate Representative; Joe Steinmeyer, Facility Manager HUB [for Todd Wingate]; John Ganim, ASUCR representative; Gary Coyne, GSA representative CAMPUS REPRESENTATIVES: Scott Corrin, Campus Fire Marshall; Earl LeVoss, Physical Plant Superintendent; Tos Ishida, Asst. Director Physical Plant and Grounds Department; John Freese, Campus Police; Nicole Seebach, student; Liliana Barcelo, student; Mike Delo, Director Transportation and Parking Services
Project No.: 1034.10	FPA: Avery Taylor Moore; Steve Lovell
Re: Focus Group Meetings	SWA: David Berkson; Amy Oliver
Location: HUB 302-UCR	RSM: Suzanne Redmond Schwartz
Prepared By: Avery Taylor Moore	Cc:

DAY ONE AFTERNOON AND DAY TWO COMPLETE: OCTOBER 27- 28, 2010

- 1. FOCUS GROUP 3: BOOKSTORE** Scott Campbell, Director; Sean Cason, Assoc Director, finance
 - Store is behind in merchandising; making do with fixtures designed and installed 18 years ago. Some are falling apart.
 - Lighting is terrible; staff added under soffit lighting along perimeter to boost lighting levels.
 - Buyback Window could be eliminated.
 - There is no money for security cameras so they will continue to use backpack storage in the rotunda to prevent theft.
 - Fraternity runs the outside backpack storage during rush. Good for the bookstore to have assistance, and the fraternity is paid for the work.
 - Gave the C-Store back to Campus Food Service when Marriott ceased being the operator.
 - The east overhang which leads to the front door tied to the architecture of the old Commons building.
 - Trees on the Commons Mall in front of the entry shed leaves, block views and are ugly.
 - Bronze glass is also not good for retailing; part of the original architectural design.
 - Sales:
 - Advertising to students online is making a big difference
 - Computer hardware is up 72% over last year
 - Coming back for apparel and textbooks
 - Tradebooks Department:
 - Being phased out, down from a high of 300-400,000/year to 30,000 year
 - Faculty are also buying less books
 - Computer Department:
 - Was under a different vice-chancellor and then returned to be part of the bookstore operations
 - Scott would like to relocate the computer department upstairs but to the south rather than to the west as proposed. Closer to the retail activity along the Commons Mall
 - Would take space previously occupied by reproduction department

Meeting Notes

UCR Commons Mall and Bookstore Renovation and Enhancement DPP

Meeting Date: October 27-28, 2010

- Department could get bigger
 - Apple will assist with design of their displays; big source of income
 - Will display gaming and tech products
 - Would like to coordinate tournaments in Latitude 55 and have products on display at Bytes café
 - Apparel Department:
 - Has the highest margins
 - Could relocate some merchandise to northeast corner of upper level
 - Loading Dock:
 - Making existing dock work
 - Bringing in smaller trucks most of the time
 - Printing is on Atlanta Avenue off of Spruce Street
 - Reprographics is there. If bookstore could have 1,000 SF storage at that location, larger trucks could stay off campus
 - Use the original conveyor belt to deliver textbooks downstairs
 - In next 5 years, would like to move remaining textbooks to first floor southwest area, and shift some apparel to the northeast corner
 - Revamped lower floor:
 - Career Center wants 8,000 SF; could have most of the downstairs
 - Would keep utility rooms and conveyor belt storage area at lower floor.
 - Toilet rooms would be expanded and shared
 - Perhaps a display window or area for computer products at the Lower Plaza Level
 - Staff offices:
 - Good office and meeting spaces
 - Small break room
 - Large conference room
 - Currently 19 staff; highest staffing level was 28
2. **FOCUS GROUP 4: CAREER CENTER** Randy Williams, Director
- Vision is to occupy 8,000 SF of lower floor in Bookstore building:
 - Will get many more students at central location
 - About 1,000 out of 5,000 incoming students need to be redirected in career paths through learning center
 - Facility should be professional and modern, not folksy; HUB satisfies this need currently
 - For comparison, UCSD has 12,000 SF serving 25,000 students
 - UCI is doing a good job with 5,000 SF and 12 staff
 - Career Services:
 - Host 300 seminars and workshops annually between September and June
 - Using HUB daily-- M-TH, 2 ½ events on average, with 25-30 people each. 1 event per week for 80-90 people
 - Currently use Rooms 265 and 269 at the HUB conference center for large student/employer gatherings; could potentially be bumped off the schedule, but reservations 1-year in advance currently working well with Todd
 - Employer information sessions last 1-2 hours
 - Largest programs for the past 4-5 years have been held in rented tents at the Arches; 7-8 per year
 - Access:
 - Visitors use shuttle service from Parking Lot 30. In future, Parking Lot 24 will be a commuter parking structure with reserve spots
 - There is a transit bus system and students are getting more savvy about its use, due to the increased critical mass of students
 - Will need drop-off near new career center location
 - There will be locational demand at the new location with good weather and the use of GEM carts
 - Employers also have to negotiate parking at other universities

Meeting Notes

UCR Commons Mall and Bookstore Renovation and Enhancement DPP

Meeting Date: October 27-28, 2010

- Existing Building Program:
 - Located away from central part of campus
 - 3,200 SF, former hospital wing with wide corridors; not all usable space
 - Added windows in existing hospital doors and increased light levels
 - Space includes: lobby; open admin area; waiting room with drop-in counseling desk, some reference books and a few computers; small kitchen; storage room for job fair supplies
 - Currently have office space for 21 staff; 1/3 work with corporate community
 - 16 private offices (some shared) are 110 SF each; could be smaller; would consider open offices
 - 3 offices are used for interviewing
 - Marketing coordinator shares workroom with scanners and layout space; use campus printing service
 - Use Skype and GoToMeeting
 - Use multipurpose rooms on campus for interviewing
 - HUB caters meals
 - Desired Building Program:
 - Central campus location
 - Light-filled space
 - Large conference room
 - Smart classroom for 50 students
 - Larger breakroom for employer groups
 - Restrooms in facility
3. FOCUS GROUP 5: CAMPUS FOOD SERVICE Cheryl Garner, Director
- Campus has met its saturation level; there is no market for food at the Lower Plaza
 - Offer several meal plans:
 - Took away Flex Max Program which served off-campus residents with nothing but Dining Dollars, but students can still get Meal Programs that include Dining Dollars to eat at HUB and other non-residential venues.
 - There is also Bear Bucks which is a declining balance card
 - Looking at website for food gifts etc, but campus cannot take credit cards which reduces sales
 - Looking closely at catering services because student funded programs should serve students
 - 2008 Housing Master Plan shows available food at that time
 - Todd selects/oversees food programs on the Commons Mall
 - Dining Choices: we reviewed a campus map with many existing locations and potential new locations for food trucks and dining venues to serve currently underserved areas of campus
 - New Bytes Café at Bourns Hall has surpassed Ivan's in profits; it provides a special environment
 - Barn expansion will expand from 100 to 325 meals/hour, with coffee house in the renovated historic cottage
 - Juice Bar at Rec Center does not get enough traffic
 - Food Emporium at A+I will offer late night venue
 - Need to provide more dessert options; working with new bakery at Mission Inn to provide cupcakes on campus
 - Maybe could do a dessert venue in Bookstore
 - Planning a Taco Fresco Truck adjacent to Orbach Library
 - Planning an organic open-air fruit truck at the Orchard, with whole fruits and vegetables and prepackaged goods every day
 - Scotty's Farmer's Market is at Glenmore weekly
 - Glenmore II –a future 800 unit apt building at Big Springs will have a C-Store, home meal replacement program, coffee house, grill
 - Good example is the awesome Stanford Marketplace, with soft seating in the C-Store
 - Kerckhoff Hall, UCLA, offers entertainment 7 times weekly

Meeting Notes

UCR Commons Mall and Bookstore Renovation and Enhancement DPP

Meeting Date: October 27-28, 2010

- Have to balance new venues with existing
 - Incoming Subway will fill the sandwich market
 - Coffee Bean serves parfaits; another smoothies vendor could reduce their existing sales
 - C store makes profit on beverages
 - Willing to test if a coffee truck could work at Lower Plaza
 -
- 4. **RECAP MEETING**
 - FPA Summary of What We Heard: Avery Moore
 - VISIBILITY -- Career Center
 - IDENTITY -- Bookstore
 - FIT – Two sides to the Commons Mall
 - SATURATION – Dining venues
 - OPEN EVENTS SPACE – HUB
 - SERVICE CONFLICTS – Deliveries
 - CONTIGUOUS FLOW -- -- Placemaking
 - SCALE-SHADE-SEATING -- Placemaking
 - Mike Delo, Director of Transportation and Parking Services
 - Service vehicles have to pass through the gate arm at Aberdeen and North Campus Drive
 - Some people know how to sneak through gate when arm is still up; time lag
 - Renovation of Parking Lot 19 will further regulate vehicular access to service drive with gate added at southeast end of parking lot; another at entrance to service drive, and another at east end of service drive at Commons Mall.
 - Thought of getting rid of Pierce loading dock but need to keep it for tank access
 - Eucalyptus trees could come down
 - Large(heavy) trucks can access Commons Mall from Rivera; this is preferred administrative route. Cannot turn around at service drive because of new pylon sign
 - Will walkways at Commons Mall be beefed up to support truck traffic?
 - Joe: Currently, PMs for events direct trucks where to go; lay down plywood for temporary Commons Mall access; do want to keep Commons Mall open as a gathering space
 - Danny: Who is designing access across service drive [not in current DPP scope]?
 - Steve Lovell:
 - Steve showed a preliminary site concept from the afternoon strategy meeting with FPA and SWA on October 27. It suggested tying new Commons Mall landscape to the existing HUB landscape, in an east-west direction, instead of relying only on the existing linear north-south expression of the Commons Mall.
 - Will integrate the east and west sides of the Commons Mall more effectively
 - This was well received by the group
 - Avery: Career Center can take the entire lower retail floor of the Bookstore, and Bookstore will move textbooks up. But both Bookstore and Career Center may want to grow in several years time. Plan now for expansion possibilities
 - Jim: FPA to provide order of magnitude cost for future expansion, including implications for capacity and functioning of existing building systems
 - Joe: Priority to repair damaged Commons Mall paving, particularly near Coffee Bean
 - Danny: Store visibility is important
 - Darius: North-south shade structure should be considered
 - Nita: There is more signage to come, including some freestanding grids in storage until the concept plan is completed
 - Danny: Need to take into account senior gifts. There is a fund for a bear statue, if an affordable version can be found. Also trees and benches. And handprints of some students which are currently in the HUB landscape.

END OF MEETING MINUTES

MEETING NOTES

Issue Date:	12/06/10	Present:	UCR: Jim Sandoval; Tim Ralston; Nita Bullock; Uma Ramasubramanian; Don Caskey; Darius Maroufkhani; Danny Kim
Meeting Date:	11/30/10		FPA: Avery Taylor Moore; Steve Lovell
Project:	UCR Commons Mall and Bookstore Renovation		SWA: Amy Oliver
Project No.:	1034.10		
Re:	Project Scope and Budget		
Location:	Telcon		
Prepared By:	ATM	cc:	David Berkson

Notes:

SUMMARY: Discussion is to review potential scope and funding for Phase 1 DPP. Numbered items below match Agenda topics and correspond to areas on attached map. Idea is to present a kit of parts at next meeting for PMT review and selection.

1,7: Commons Mall improvements:

- Darius: Initial reaction is to do some of all the items in the first phase
- Tim: Q. Does this direction dovetail with Todd's goals? ATM: A. Yes; that is the intention
- Nita: Todd did express the desire to keep Commons wide open for HEAT
- Danny: Daily activities will override a 1 time event, but we should keep the Commons somewhat open so that the network of campus open spaces is apparent; don't break the Mall apart into several pieces.
- Danny: Because building expansion next to the Bell Tower could be in the very near future, do not spend money to enhance this area now
- Nita: Todd thought the potential building pad at this location was too small
- Jim: We will need to add building at this location at some point. The Mall should be open for smaller fairs
- Nita: We can accomplish this by removing the existing trees and planting less and larger trees which will provide shade but keep the space more open
- Jim: Likes the idea of more trees
- Danny: Wants to keep a long stretch of space available in north-south direction
- Avery: SWA concept is to connect east-west across Commons to tie to existing Hub landscape and pathways. Do we extend east to the edges of the sciences buildings now or later?
- Jim: Take advantage of the opportunity to provide private seating along the science building edge. This is a great opportunity and preserves some of the open area
- Jim: Don't make the main area too sparse; do not just extend the umbrella look

8. Service Drive:

- Danny: Saw Lot 19 project update including crosswalk. Should probably move to this project
- Darius: Existing crosswalk across drive meets ADA, but the slopes on the Surge side (north) do not comply
- Nita: Makes sense to transfer this part of the Lot 19 project to this Commons Mall project

Meeting Notes

Project Scope and Budget

- Don: This project is covering the center Service Drive area; need to talk with Mike and Mike about service and safety. Gates and an intermediate dock nearer to the Hub loading dock are being considered [Note: Service Drive improvements are currently outside scope]
- Nita: We should also consider earlier delivery hours
- Jim: The ASUC should not own this project
- Danny: Maybe FPA looks at overall crossing but as part of the Lot 19 project
- Avery: The project team could look at concept layouts for ramping on Lower Plaza side and not take on the engineering and safety solutions for the service drive itself
- Nita: Working on ramping/crossing will expand FPA scope

6. Improvements along North Campus Drive:

- Jim: Yes, add graphics along North Campus Drive
- Danny: Also Banners for HUB events, connection to Lot 24
- Jim: Should be some pedestrian entrance features at Commons Mall entrance and Lower Plaza entrance
- Steve: Part of concept is to make the stairs from engineering more straightforward
- Danny: Not enough in budget to fix stairs up from Engineering Building
- Nita: Could make pathway more pleasant with landscaping but keep existing infrastructure
- Don: Kit of parts is good idea. Agree with Danny need to know whose cost covers improvements

-- Overall Project Budget:

- Danny: Overall project budget is \$4-6M. Assuming soft costs of 22%, that is a \$4.5M hard construction cost. Assuming 50% from Commons reserve and 50% from reg fees. This money is reserved, but is there a possibility of financing part of this?

4,5 Relocate Career Center and reconfigure Bookstore:

- Avery: Program is to give the Career Center 8,000 SF +/- on the lower level, including a large conference/meeting room, and for Bookstore Computer Center to occupy the former Reprographics Space on first floor (allowing a reduced textbooks area to move up to the First Floor).
- Danny: HUB is filling up; cannot dedicate space in HUB for Career Center meetings, but conference room is a luxury item, not in original program.
- Avery: Q. Could a conference space be reserved for Career Center in the Surge Building? Danny: A. No
- Danny: Program has to include an 800 SF card office at lower level of Bookstore building, improved walkways and equipment purchase.
- Nita: Q. Can card office move elsewhere? Danny: A. Want connection to the Career Center; needs a front customer service counter. Performs lots of cash transactions, a bank teller function.
- Steve: Q. Could card office part of Marketplace? Danny: A. Only really busy certain times of year.

2. Lower Plaza, west of stairs, south of lecture hall; work extends to east side of Surge Building:

- Nita: Want a flow
- Don: Softer edges good; the Art Complex is coming [will eventually replace Parking Lot 19]
- Avery: Should we be suggesting areas for future expansion of Bookstore building?
- Danny: Career Center relocation is first priority
- Don: No problem to look at two phases of work; this is about what we can do
- Danny: Financial pro-forma over a couple years so we should not count on future funding
- Avery: Phase 1 scope should look complete

3. Latitude 55 Storefront improvements

- Conceptual storefront design will be part of DPP scope

MEETING NOTES UCR COMMONS MALL AND BOOKSTORE RENOVATION

Issue Date: January 27, 2011	Present:
Meeting Date: January 13, 2011	UCR/PMT: Jim Sandoval; Danny Kim; Don Caskey; Jacqueline Norman; Tim Ralston; Nita Bullock; Ulma Ramasubramanian
Project: UCR Commons Mall and Bookstore Renovation and Enhancement DPP	UCR / COMMITTEE: Scott Campbell, Director Bookstore; Cheryl Garner, Director Food Service; Randy Williams, Director Career Center; Todd Wingate Director HUB;; John Faheem, ASUCR representative CAMPUS REPRESENTATIVES: Earl LeVoss, Physical Plant Superintendent; Tos Ishida, Asst. Director Physical Plant and Grounds Department; Mike Delo, Director Transportation and Parking Services
Project No.: 1034.10	FPA: Avery Taylor Moore; Steve Lovell; Paul Cooper
Re: Task 5 Meeting	SWA: David Berkson; Amy Oliver
Location: HUB 302-UCR	FPA Consultant Team: Neha Yardav, KPFF civil; Kelly Weldon, NYASE structural; Tony Cocea, Zelik Uber, IBE mechanical; Paul Carey, OMM electrical
Prepared By: Avery Taylor Moore	Cc: Suzanne Schwartz, RSM

MEETING WITH PMT AND CONSULTANTS – 9AM - 10AM

- Nita: Want to be in front of Design Review Board (DRB) the first week of February, and CPAC the third week in February. Top priorities are to relocate Career Center, improve the Commons Mall, and address the Lower Plaza. DPP will establish the project scope, with some phasing options.
- Danny: Not a lot of hope to go past the current project budget [estimated \$4.5M hard cost]
- Avery: We have preliminary rough estimates from Davis Langdon that show \$250/SF for interior bookstore renovations and some façade improvements; this does not include major utility upgrades.
- Jim: If we were to consider relocating the main stair, what would the cost be? Avery: Not known, but based on a first pass estimate by Davis Langdon, the project budget would likely have to double.
- Nita: Is the main purpose of the relocation to call attention to the building? Avery: Yes; and by doing so, to extend the HUB.
- Nita: Will the bookstore move in the future? [no answer]
- Jim: We will need other student services to extend the HUB outward- the campus store will be one beacon within the beacon [the larger HUB District].
- Jacqueline: The Lower Plaza is a very busy back door to the HUB, so expanding/improving the north side will help.
- Steve: There are limited areas to expand the existing building footprint for more uses or expanded uses.
- Jim: the amount of students coming to the Hub from Material Sciences. Just the expanded foot traffic crossing the street [North Campus Drive].
- Danny: To do it right and expand the HUB would require another referendum.
- Jim: So is this our shot?
- Tim: Not necessarily. \$4.5M is near term.
- Danny: Can we talk to the campus about an \$8M project. If limited by current budget, could be years before additional funding is available. Is a loan possible?
- Jim: Not in my lifetime.

Meeting Notes

UCR Commons Mall and Bookstore Renovation and Enhancement DPP

Meeting Date: January 13, 2011

- Tim: This is a conversation worth having.
- Jim: Definitely.

SITE MEETING – 10AM - 12Noon

1. David Berkson, SWA Presentation:

- David Berkson showed a series of slides and stated that shade is the most important factor, with places to sit in configurations that promote conversation. Should be a variety of arrangements.
- There must be a notion of context- how to knit this project into the larger campus picture and tie to the HUB landscape.
- The Commons Mall should provide a north-south promenade (like the other campus malls) but also weave in east and west connections.
- Need to pay close attention to the ground plane- the continuity and choreography of “gardens” which are part of the campus heritage and visible in the Botanic Gardens.
- A single heritage tree can give the HUB “weight.”
- Two concept options were shown for programming the Commons Mall. Both were illustrated with an overlay of primary axes leading to and from the HUB complex. These included new angled pathways and view corridors from the Highlander Union Plaza southeast to the Bell Tower and northeast to the mountains
- OPTION ONE:
 - The Commons Mall has two north-south walks: one along the west edge that is 40-foot wide next to retail and closest to the HUB; and one along the east side that is 20-foot wide to access the Science Courts and become a fire lane adjacent to Bourns Hall.
 - The south half of the mall is a softer green passive space; the north half is a “forecourt” to the Bookstore, 50% hard, and 50% soft.
 - At the south edge, there is a 5-6,000 SF events court which mirrors the scale of the Bell Tower parcel, and aligns with the HUB Plaza on the west and Pierce Hall frontage on the east.
 - At the far north side, tree canopies should provide shaded garden spaces.
- OPTION TWO:
 - This concept favors the west walk, and a large treed garden area “grows” out of the existing HUB landscape. There is a sustainable low maintenance understory.
 - This is similar to a more traditional campus quad, with angled pathways through the green space.
 - An 18-inch high seat wall will surround the central part of the green space, surrounding the heritage sycamore trees to remain, and providing viewing and seating space for students.
 - The north side of the bookstore might have a water wall.
- David showed a series of images illustrating ground planes and pathways, landscape forms, ways to define space, choices for seating, relaxing or studying, and use of water.

2. Initial Comments:

- Avery: Is there an events space in Option Two? David: I do not see it here. Could use the existing hardscape in front of the Bell Tower.
- Danny: Is the quad sloped with raised hills? David: No, more or less flat. Not a lot of room for changes in topography.
- Todd: Option One does not appear to add a layer for student related activities. There are up to 400 student associations wanting space. Have not accommodated big events. Option Two looks even more problematic.
- David: You could remove all the green under the trees in Option One and have a large hardscape event space. Todd: In Option One, you are pushing the activity space towards the Bookstore, moving noise towards the faculty in Bourns which will not be good. May be should flip hardscape towards Bell Tower.
- Jim: Not sure I agree. David: You could do that.
- Todd: Important to keep the Sycamores in Option One. David: Yes; keeping named trees.

Meeting Notes

UCR Commons Mall and Bookstore Renovation and Enhancement DPP

Meeting Date: January 13, 2011

- David: When there is no activity, the Commons Mall also has to be a place.
- Jim: I like the idea of being able to use the Science Arcades. There are student groups who can claim these spaces.
- Nita: Would you have a permanent canopy at the center space? David: You could.
- John: Biggest concern is the high traffic coming out of Bourns. "Tabling" outside the Bookstore is not working; people are running past this zone. The Highlander Union Plaza is the place people go; people stay close to the action.
- Jim: I have a different perspective. Departmental offices are not large enough; don't necessarily need broad exposure. The Tables at the Bookstore have become smokers central.
- Danny: I like the spaces to hang out and the scale of the gathering spaces, especially the upper right image [on Board 6].
- John: We need spaces supplemental to the Bell Tower. Need dancing space on concrete, and places to chalk the sidewalk. There is some Associated Students money for adding benches to the Commons Mall.
- Cheryl: The Subway vendor needs some outdoor seating; too small for indoor seating.
- Steve: Will need shade at this location
- Todd: Consider the space between Costo and Sass- could be repurposed as hang-out space. Jim: The Fire Marshal said no to this area since it is a fire lane. John: Pan-Hellenic groups practice dancing here.

3. DRB Review:

- Don: For the DPP, we are reviewing concepts from a programming rather than specific design standpoint.
- Danny: Bottom line is which direction to go in. Typically, DPP is bubble diagrams with adjacencies.
- Don: The DRB will look at the information to determine if the design concepts can deliver the program objectives. It is a delicate dance because some design is necessary to test the site, but you have to tread lightly on design. DRB may give other reinforcing observations.
- Nita: The objectives are to
 - Relocate the Career Center
 - Upgrade the Commons Mall
 - Make the Lower Plaza work
 - Reposition the bookstore
- Don: Agree. We are looking for the big picture; the skeleton of design. Show a preferred direction but show how we got there from Options One and Two. Hit on program not design.
- John: What is the makeup of the DRB? Don: Don is the chair; Tim is on it; 3 members from outside, serving on a 3-year basis; 1 architect selected by the Chancellor on a 1 year basis—on sustainable side; 3 members from the campus; 1 student representative.

4. Individual Preferences:

- Steve: Likes visual axis of Option One. Can we make connection at Bookstore to the mountains? Bookstore needs visibility; make trees here looser. Lower grade at north side of Lower Plaza; provide more presence for Career Center.
- John: Likes Lower Plaza improvements.
- Scott: Need to slow people down in front of the main store entrance.
- Randy: There are many more students coming across the bridge from MS&E.
- Uma: Likes vectors. Prefer Option One. Has structure, but can morph. Informality of Option Two is nice but we may need more program space.
- Jacqueline: Agree with Uma. Option One provides a consistent University Park feel with Bell Tower. At the same time, there are intimate spaces along the east edge. Concerned that the northwest edge of Surge needs to be programmed.
- Todd: Option One achieves a lot of what we talked about; will help us achieve our goals for Commons Mall; need to improve infrastructure. Worry about the visual barrier to the Bell Tower in Option Two. Like the open and linear quality of One; thinks students will like it. (Can we also look at bicycle parking?)
- Nita: Also likes the East and West corridors through Mall, with different activities between them. And the private east gardens. Will be limiting lots of car traffic through the site. Will need plans for bike corrals.

Meeting Notes

UCR Commons Mall and Bookstore Renovation and Enhancement DPP

Meeting Date: January 13, 2011

- Danny: Trees with people walking under them resonate. Opportunity here for long stretch of open space. Also likes Option Two- reads it as direct access to the Bell Tower and gardens.
- Steve: Option Two is a bigger, bolder move.
- Avery: Need to have visibility for campus security.
- Jacqueline: Would rather come across this by surprise.
- John: Students take same path—both pedestrians and bikes, so Option Two confuses me. Olmstead's direct paths were easy to read; the HUB has put a different feel on campus. Danny: I agree.
- Don: Seeing Option Two for the first time. Will defer to colleagues. Perceived wayfinding is a strong point of the campus. The mature landscaping is another key factor; buildings in many ways are a backdrop. On West Campus, Gage Canal Mall is sinuous, adds another type of energy and can bring excitement; Option Two may have this. How this articulates will make Don's decision.
- Cheryl: Sees the functionality of Option One. Resonates with Two. Works with the HUB complex. Looks like a great place for informal picnics It is different; will be unique and special.
- Don: Option Two feels less like a Mall.
- Randy: Form follows function. Problems with students cutting across lawns. Lower Plaza is the most important for the Career Center.
- Avery: David will integrate parts of both options. Option Two seems to continue the isolation of the Bookstore. Curved paths are nice reaching from Hub over to the Science gardens. Would move some of the "slow-down" green space to the bookstore end to better integrate it into the district.
- Nita: There are 3 options for going north: The Arts Mall, Science Way and the Commons Mall. Option Two may fractionate the north-south connection.
- Todd: Students will take the straight shot.
- Don: Space between Revere and Watkins is wider, with green space flanked with walkways on both sides. At this location, as Nita says, we may not be able to read the north-south axis [in Option Two].

BOOKSTORE AND CAREER CENTER BUILDING MEETING – Noon – 2PM

1. Steve Lovell, FPA Presentation:

- Steve showed a scope diagram of the DPP to date, which includes the Commons Mall, Bookstore Building and the Lower Plaza. The scope has been extended to include some master plan concepts for the Science Gardens, extensions from both the Commons Mall and the Lower Plaza to the North Campus Drive; and concepts for a uniform approach to pedestrian intersections along North Campus Drive and across the existing service drive between the Bookstore and the HUB complex.
- Steve then showed existing building upper and lower floor plans, and two possible options for accommodating the career center on the lower level; option 2 added an 800 SF +/- card center, reducing the Career Center meeting room from approximately 1500 SF to 700 SF.
- All public bookstore operations will relocate to the upper level of the building with primary access off the Commons Mall. The former reprographics department is incorporated into the bookstore sales area.
- UCR has requested that the existing stairway that cuts through the building be opened to allow through traffic from the lower level entrance [currently closed] up to the main floor and out to the Commons Mall. This cross-through will require a new accessible elevator serving both levels, and security along the open passage. The Bookstore sales floor will be divided, with separate security and checkout for each side of the cross-through zone.
- Another separate diagram showed approximately 3,000 SF of expansion at the upper level, projecting under the existing southeast overhang, and out onto the northern plaza.
- A colored landscape diagram illustrated general programming concepts.
 - At the upper level entrance, trees and hardscape are realigned for more direct visibility and access to the store entrance.
 - At the Lower Plaza, the site grade is lowered [requiring confirmation of utility relocations], to create a programmable seating and courtyard zone adjacent to the career center, and circulation paths in both east-west and north-south directions.

Meeting Notes

UCR Commons Mall and Bookstore Renovation and Enhancement DPP

Meeting Date: January 13, 2011

- A new hardscaped entrance is provided at the north entrance to the Card Center and the Career Center meeting space.
- Concept massing studies were shown of the new lower entrance to Career Center and Bookstore, and of the possible upper level expansion.
- A preliminary concept for signage and new storefront at Latitude 55 was also illustrated.
- Randy: The "library-resource area shown is needed for students to have a place to plug in for information.

2. Existing Building Systems

- Civil – Neha Yadav, KPFF
 - Gas Line: Discussed moving gas line to be able to lower the grade at the lower plaza. This will allow the windows of the building to extend lower, providing more daylight and views into the new career center.
 - Existing drawings: Civil will provide a composite drawing of existing site utilities; FPA will put together a list of drawings to complete the existing examination.
- Mechanical – Tony Cocea and Zeilik Uber, IBE:
 - There is available capacity for adding career and card functions to the building. But we have the "wrong" system to get 20% below Title 24 [general campus standard].
 - Can deliver different zones, but the system is full of dirt and rust.
 - We will look at an all new system, a make-do system, and a hybrid system for cost purposes.
- Electrical – Paul Carey, OMM:
 - System: 480 volt, 12KV
 - Switchboard: Looks pretty good. 300 kva transformer
 - Lighting: Will need all new; existing is not bright enough for retail. Can hit or better Title 24 for lighting
 - Daylighting: Can reclaim some daylight with more controls
 - Life Safety: Need a new intelligent panel
 - Telecom: Requires rewired head ends
 - Closed circuit TV: Should be a new system
 - Security system: Need more intelligence in the head end
 - Muzak: Reshuffle zones.
- Structural – Kelly Weldon, NYSE
 - Cantilevered retaining walls could be demolished. If structural capacity is reduced less than 10% no structural analysis is required for the full building.
 - To balance new openings in exterior walls, will need to put an equivalent amount of structure back in the same wall.

3. Comments

- Nita: Could the card center be relocated where existing toilet rooms are located:
- Cyndi: Card center requires space for 2-5 staff, 2 offices, counter to serve 3 students, queuing space. Service is through front door, but good to have access to career center and shared back of house functions.
- Randy: Intrigued with plaza access to multipurpose meeting room. Could have small after hours receptions. Plan accommodates what we need.
- Scott: Elevator is taking up too much retail floor space for bookstore. Will need electric gates at entrance to stop theft through elevator.
- Danny: Need to keep view from upper level of bookstore to the mountains
- Scott: Wants to put apparel on north side, without more windows. Store expansion east will be second phase.

PHYSICAL PLANT MEETING – 2PM – 3:30PM

- Dave: Mark trees to preserve at Lower Plaza; not too many.

Meeting Notes

UCR Commons Mall and Bookstore Renovation and Enhancement DPP

Meeting Date: January 13, 2011

- Tos: Canary Island palms were planted in 1959. One is very near the gas line. Need to preserve campus history.
- Don: We should explore relocating the gas line since the plaza is an important part of the desired program. Code issues should be included for the real cost. Need to maintain fire access to the Lower Plaza.
- Danny: Need to create a real plaza in this area that is programmable space. The diagrams suggest large raised planter areas that appear to be taking up too much space.
- Service Aisle:
 - Mike: Likes the idea of an elevated speed table for pedestrians, to slow vehicles down.
 - Nita: This is an important pedestrian pathway
 - Don: Speed table with lights, stop signs, 2 mph speed limit, and gated access past the service point for HUB. Speed table will keep students on the pathway.
 - Avery: Design will require civil engineer with specific traffic expertise.
 - Cheryl: Service vehicles for Activity Center and retail food tenants have to come all the way up drive.
 - Don: Maybe we need to redesign the loading dock serving the Activity Center.
 - Mike: We need to repackage service in this area.
 - Todd: We may need to put in an equipment elevator.

SUMMARY MEETING – PMT AND COMMITTEE – 3:30PM – 4:15PM

- FPA/SWA to have a draft DRB powerpoint by January 21 for UCR review. Focus on programming of space. Will have a preliminary gotomeeting with PMT prior to the DRB presentation which is slated for February 1, 2011..

**UC Riverside
Design Review Board
Meeting Minutes for February 1, 2011**

Board Members		
Professor John Ganim	Academic Senate Chair, Physical Resources Committee	(N)
Professor Stella Nair	History of Art (CHASS)	(A)*
Professor Jerome Schultz	Bioengineering (BCOE)	(N)
Professor Linda Walling	Botany & Plant Sciences (CNAS)	(A)
Timothy Ralston	Associate VC, Capital & Physical Planning	(A)
Don Caskey	Associate VC/Campus Architect, Design & Construction	(A)
Charles "Duke" Oakley	Steven Ehrlich Architects	(N)
Rob Quigley	Robert Wellington Quigley, FAIA	(A)
Norberto Nardi	Nardi Associates	(A)
Presenter(s)		
Avery Moore	Field Paoli	(A)
Steven Lovell	Field Paoli	(A)
David Berkson	SWA	(A)
Amy Oliver	SWA	(A)
Tom Whetstone	HDR	(A)
Mike Rodriguez	HDR	(A)
Other Attendees		
Rich Racicot	Office of Design & Construction	(N)
Mike Delo	Transportation & Parking Services	(N)
Mike Miller	Facilities, Plant Administration	(N)
Kieron Brunelle	Capital & Physical Planning	(A)
Uma Ramasubramanian	Capital & Physical Planning	(A)*
Tricia Thrasher	Office of Design & Construction	(A)
Nita Bullock	Capital & Physical Planning	(A)
Jacqueline Norman	Office of Design & Construction	(A)
John Cook	Office of Design & Construction	(A)
Andrew Stewart	Transportation & Parking Services	(A)
Russell Vernon	Environmental Health & Safety	(A)
Susan Ryan	Office of Design & Construction	(A)
Sandi Evelyn-Veere	Office of Design & Construction	(A)

Attendance (A = Attendance, A* = Arrived After Presentation, N = Not in Attendance)

- 1.0 Meeting Agenda. The agenda for the February 1st meeting of the Design Review Board (DRB) included:
- a. Commons Mall & Campus Bookstore Renovations & Enhancements, Pre Design Study (DPP), and
 - b. Environmental Health & Safety Expansion Building, Schematic Design.
- 2.0 Announcements
- a. Student Recreation Center Schematic Design will be presented to DRB at an upcoming meeting.
- 3.0 Observations and Recommendations – Commons Mall & Campus Bookstore Renovations & Enhancements, Pre-Design Study (DPP) The DRB made the following recommendations:
- a. The malls need to have a strong sense of space and an identity that promotes a place for people to congregate and meet. The two malls should equal one another – one of movement and one for congregating and a place of sanctuary. DRB felt the current plan didn't show a strong enough gesture for the malls.
 - b. The Bookstore renovation needs to address potential glare issues in the building. Overhangs, non-glare glass and back lighting should be studied.
 - c. The service road is a challenging part of the plan; attempt to avoid conflicts but don't sanitize it.
 - d. The Board felt that the citrus heritage of the campus should be incorporated into the current plan by adding citrus trees to the landscape plan.
 - e. Shade structures and arcades are welcome and part of the UCR tradition.
 - f. The Board suggested that the design team explore another scheme where the central space becomes the central protagonist (semi-covered) connecting the enclosed spaces and creating a “ shaded” community space.
- 4.0 Observations and Recommendations – Environmental Health & Safety Expansion Building, Schematic Design. The Board made the following observations and comments:
- a. The Board felt that the courtyard area on the north side of the building should be relocated in order to make a natural connection to the building. Its current location does not provide shading in the Summer months or sun in the winter and it may be better located on the south side near the training room.
 - b. DRB felt there was not enough definition between the two wings and the entry form; the canopy area shape seems wrong in how it mediates between the two building masses and should be re-thought. The proposed enclosed lobby could be smaller incorporating semi-covered spaces as entry way and potential outdoor expansion of the meeting areas. Rock landscaped areas near the building will store heat and should be moved further away from the building.
 - c. Don Caskey indicated he would like HDR to return to a future DRB meeting with a redesign of the entry and outdoor spaces.

4.0 Follow Up and Next Steps.

a. The DRB meeting scheduled for March 1, 2011 was cancelled. The next DRB meeting is scheduled for April 5, 2011.

The following constitutes a summary of topics presented to or discussed by the DRB on February 1, 2011. Recipients of these minutes are encouraged to apprise Susan Ryan of any errors or omissions.

MEETING NOTES

UCR COMMONS MALL AND BOOKSTORE RENOVATION

Issue Date: March 31, 2011	Present:
Meeting Date: March 29, 2011	UCR/PMT: Jim Sandoval; Danny Kim; Jacqueline Norman; Tim Ralston; Nita Bullock; Ulma Ramasubramanian
Project: UCR Commons Mall and Bookstore Renovation and Enhancement DPP	FPA: Avery Taylor Moore; Steve Lovell
Project No.: 1034.10	SWA: David Berkson; Amy Oliver
Re: Cost Estimating Meeting	
Location:	
Prepared By: Avery Taylor Moore	Cc: Don Caskey; Suzanne Schwartz, RSM

MEETING SUMMARY

1. Priorities: There was general agreement on the order of project priorities:

1. Career Center relocation
2. Bookstore reconfiguration
 - a. Open stair
 - b. Add elevator
 - c. New Comp UCR store at old reprographics location
3. Commons Mall improvements
4. New Latitudes storefront
5. Lower Plaza improvements
 - a. Service drive improvements will be part of parking lot 19 scope]
6. Small Courts east side of Commons Mall
7. North Campus Drive

Danny noted that the Career Center relocation has to include the Bookstore Reconfiguration and Improvements so this line item was moved up from 3 to 2.

2. Handouts: FPA provided a bound copy of the Draft Cost Estimate and Technical Narratives; and 11" x 17" handout of concept drawings from individual disciplines.
3. Budget: We landed on an approximately \$8M DPP scope, including 20% soft costs. Jim and Danny are going to approach the governing board to see if the project cost can be increased from \$6M to \$8M.
4. Building: We agreed to use Option 1 for the Bookstore as the improvement basis, including lowering the first bay of windows at the Lower Plaza [to be added]. See pages 5 and 6 of cost summary, Section 2 Cost – Bldg. Option 1; and Architectural Narrative. Scope as estimated includes new interior build out for Career Center and Card Office, including new accessible toilet rooms; new elevator and elevator lobby addition; new finishes and lighting at stairs and Rotunda; limited new finishes and electrical in Bookstore; new AHU and limited new ductwork; limited sprinkler modifications.
5. Landscape: We agreed to a total of \$3M plus an allowance of \$200K for the trellis. See page 8 of cost summary; Section 4: Landscape Cost; and Landscape Narrative. Scope as estimated includes all new light fixtures with power outlets for events; all new irrigation and controller; all new paving estimated as concrete pavers suitable for truck traffic; all new ground cover and plantings on commons mall, except for Sycamores to remain; custom benches and some freestanding furniture.

Meeting Notes

UCR Commons Mall and Bookstore Renovation and Enhancement DPP
Cost Estimate Meeting Date: March 29, 2011

- a. Total estimated cost for all landscape zones: \$4.454M
 - b. Retain Zones A, B, C, D, E, J, L and Trellis= \$3.849M
 - c. Delete Zones F, G, H, I, K, and Service Yard gates [under Parking Lot 19 improvements] = <\$.605K>.
 - d. Reducing landscape contingency from 15% to 10 % reduces overall multiplier from 39.62% to 33.62 % for a revised landscape total of \$3.6M.
 - e. Team agreed to work with \$3M for all landscape and \$200K for trellis allowance, requiring \$400K additional savings to be found to cover both the landscape scope and the trellis.
6. Signage: RSM provided illustrations for sign concepts and a preliminary budget for sign fabrication and installation; Davis Langdon added markups to these totals on p. 6 of the Cost Summaries. See Section 5: Cost - Signage and FF&E, and 11 x 17 illustrations starting on page 19 (RSM #8 through 21). We discussed a Latitude storefront budget of \$145K based on pricing listed as Entry 2 on page 57 of the cost estimate. Jacqueline noted that the tickertape shown on RSM dwg#17 is not in the current HUB signage budget so would be part of new cost if selected. We also discussed an allowance of \$150K for signage at the Bookstore Building; signage framework on exterior of Bookstore building is included in the Building Option 1 estimate. Building signage will include signs at Conference Room and Card Office doors at Lower Plaza. Additional HUB wayfinding and pylon signs are not included in the \$150K allowance.
7. FF&E: The initial budget of \$420K was provided by Dick Kremer, bookstore consultant, and was based on \$35 SF, including reuse of existing textbook shelving. This estimate was reduced by \$45K to \$375K, assuming reuse of some additional existing fixtures.
8. Cost Breakdowns: We are going to ask Davis Langdon to break out several scopes for review and for possible add alternates. These include:
- a. Total cost of elevator work, including the new building lobby
 - b. Lowering first window bay at Lower Plaza only to include in Option 1 [cost to be added]
 - c. Total cost of relocating the gas line and lowering all northwest facing windows at Career Center
 - d. Total breakout of Lower Plaza landscape and site work
 - e. Confirmation that excavation costs for site work are adequately covered
9. Proposed Project Scope: The estimated scope at our meeting was as follows:
- | | |
|--------------|---|
| \$3.627 M | Building Option 1; see Architectural narrative for build out |
| .145 | Latitudes Storefront allowance |
| .150 | Partial signage package to cover all building signage and limited site signage |
| <u>3.200</u> | Landscape package including trellis; east courts are a future phase; north campus drive frontage and service drive not included |
| \$7.122 M | Hard Construction Cost [I had this at \$6.122] |
| 1.424 | 20% Soft Costs |
| <u>.375</u> | Bookstore FF&E allowance; reduced Dick Kremer's \$420K estimate by \$45K |
| \$8.921 M | Total project cost [I had this at \$7.9M] |

Meeting Notes

UCR Commons Mall and Bookstore Renovation and Enhancement DPP

Cost Estimate Meeting Date: March 29, 2011

10. Inclusions: The list of inclusions in the cost estimate is included on P2 of the Cost Estimate Summary.
11. Exclusions: We discussed the following exclusions from the preliminary estimated project cost; see exclusions on P4 of the Cost estimate summary for more complete list:
- a. No new glazing at existing bookstore windows to remain
 - b. No new roofing or roof drain relocations
 - c. No tax or shipping in current Bookstore FFE numbers
 - d. No interior Bookstore graphics
 - e. Career Center FF&E by others including freestanding workstations
 - f. No CCTV cameras
 - g. No AV equipment for public address system
 - h. No window coverings
 - i. No bike parking or retail pads along North Campus Drive frontage
 - j. No temporary bookstore facilities during construction

POSSIBLE COST REDUCTIONS

Reductions to address the shortfall were discussed on Thursday March 31, 2011 with Patricia Djojopranoto of Davis Langdon and could be as follows:

\$.100	Reduce design contingency for building from 15% to 13%
\$.100	Reduce escalation by 2% revising start date from Dec 2013 to Jun 2013
\$.015	Reduce electrical fixture cost from \$15.50 to \$14/SF at Career Center
\$.012	Reduce stone tile cost from \$20/SF to \$16/SF
\$.011	Keep existing music system
\$.093	Delete movable tables and chairs from landscape budget
\$.200	Bid trellis as an add alternate
<u>\$.220</u>	Reduce landscape scope further; note that the current scope above still requires other savings to be found; gas line relocation and lowering windows are not within project budget
\$.751	Hard Construction Cost savings
.150	Soft Cost savings
<u>\$.025</u>	Reduce additional bookstore FF&E to a revised total of \$350K
\$.926 M	

\$7.995 M Project Budget

NEXT STEPS

Field Paoli will review the Proposed Project Scope with the consultant team and prepare the preferred plans for client review and presentation to CPAC. Some sections of the DPP will be drafted for client review; these will be modified by client and CPAC comments. The proposed DPP drawings will illustrate the concept design which will include master plan concepts for the east courts and frontage along North campus drive even though these areas of work will be outside of the scope for the DPP. Refinements to individual areas of work will be part of schematic design.



FIELD
PAOLI

